



PROJECT STATISTICS				
SITE STATISTICS				
CIVIC ADDRESS:	332 E 24TH ST. NORTH VANCOUVER - LOT B			
LEGAL DESCRIPTION:	LOT 20, BLOCK 218A, DISTRICT LOT 546, PLAN 3376			
P.L.D.:	012-962-601			
ZONE:	RS2			
SITE AREA (SQ.FT.):	2,853			
SITE WIDTH (FT):	25			
PROJECT STATISTICS				
HOUSE				
	PERMITTED/REQUIRED		PROPOSED	
	IMPERIAL	METRIC	IMPERIAL	METRIC
RIDGE HEIGHT	33	10.06	32.96	10.05
TOP PLATE HEIGHT	26.2	7.99	24.83	7.57
FRONT YARD SETBACK	15	4.57	15	4.57
EAST SIDE YARD SETBACK	4	1.22	4	1.22
WEST SIDE YARD SETBACK	4	1.22	4	1.22
REAR YARD SETBACK	39.95	12.18	43.13	13.15
ACCESSORY BUILDING				
	PERMITTED/REQUIRED		PROPOSED	
	IMPERIAL	METRIC	IMPERIAL	METRIC
ROOF HEIGHT	22	6.71	23.44	7.14
SETBACK TO SFD	10	3.05	19.13	5.83
EAST SIDE YARD SETBACK	2	0.61	4	1.22
WEST SIDE YARD SETBACK	2	0.61	2	0.61
REAR YARD SETBACK	4	1.22	4	1.22
FLOOR AREAS				
	PERMITTED/REQUIRED		PROPOSED	
FLOOR	AREA (SF)	AREA (M2)	AREA (SF)	AREA (M2)
BASEMENT			952	88.44
MAIN FLOOR			886	82.31
2ND FLOOR			856.1	79.53
ACCESSORY - GARAGE			380	35.30
ACCESSORY - GARAGE SUITE			380	35.30
TOTAL SQ.FT.			3454.1	320.89
G.F.A EXEMPTIONS				
	PERMITTED/REQUIRED		PROPOSED	
EXEMPTION	AREA (SF)	AREA (M2)	AREA (SF)	AREA (M2)
BASEMENT			952	88.44
ACCESSORY			760	70.60
TOTAL EXEMPT FROM GFA			1712	159.04
G.F.A				
	PERMITTED/REQUIRED		PROPOSED	
	AREA (SF)	AREA (M2)	AREA (SF)	AREA (M2)
TOTAL G.F.A	1,426.68	132.54	1742.1	161.84
SITE COVERAGE - HOUSE				
	PERMITTED/REQUIRED		PROPOSED	
	AREA (SF)	AREA (M2)	AREA (SF)	AREA (M2)
AREA OF HOUSE			919	85.38
TOTAL SITE COVERAGE (MAX 30%)	856.005	79.52	919	85.38
SITE COVERAGE - COMBINED				
	PERMITTED/REQUIRED		PROPOSED	
	AREA (SF)	AREA (M2)	AREA (SF)	AREA (M2)
AREA OF HOUSE			919	85.38
AREA OF ACCESSORY			380	35.30
TOTAL SITE COVERAGE (MAX 40%)	1141.34	106.03	1299	120.68

LOT B

332 E 24TH ST. NORTH VANCOUVER

- A100 - SITE PLAN
- A101 - FOUNDATION PLAN
- A102 - BASEMENT FLOOR PLAN
- A103 - MAIN FLOOR PLAN
- A104 - 2ND FLOOR PLAN
- A105 - ROOF PLAN
- A106 - ELEVATIONS - NORTH & SOUTH
- A107 - ELEVATIONS - EAST
- A108 - ELEVATIONS - WEST
- A109 - SECTIONS & ASSEMBLIES
- A110 - DETAILS
- A111 - F.A.R
- A112 - GARAGE ELEVATIONS
- A113 - CONTEXTUAL VIEWS

WWW.ROBERTBLANEYDESIGN.COM

604-626-6020

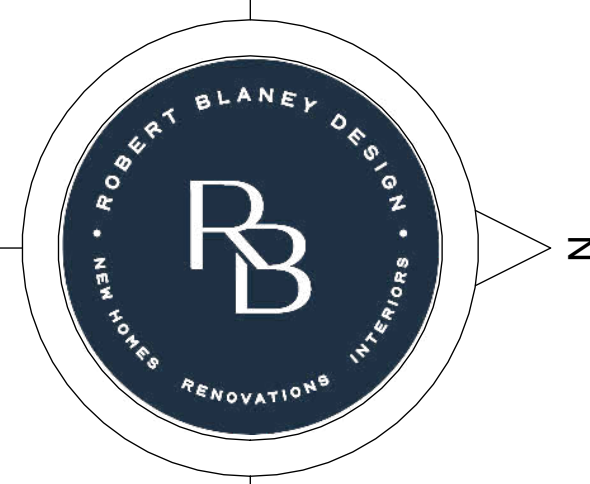

CLOSEST FIRE HYDRANT
APROX. 95.31m FROM PROPERTY

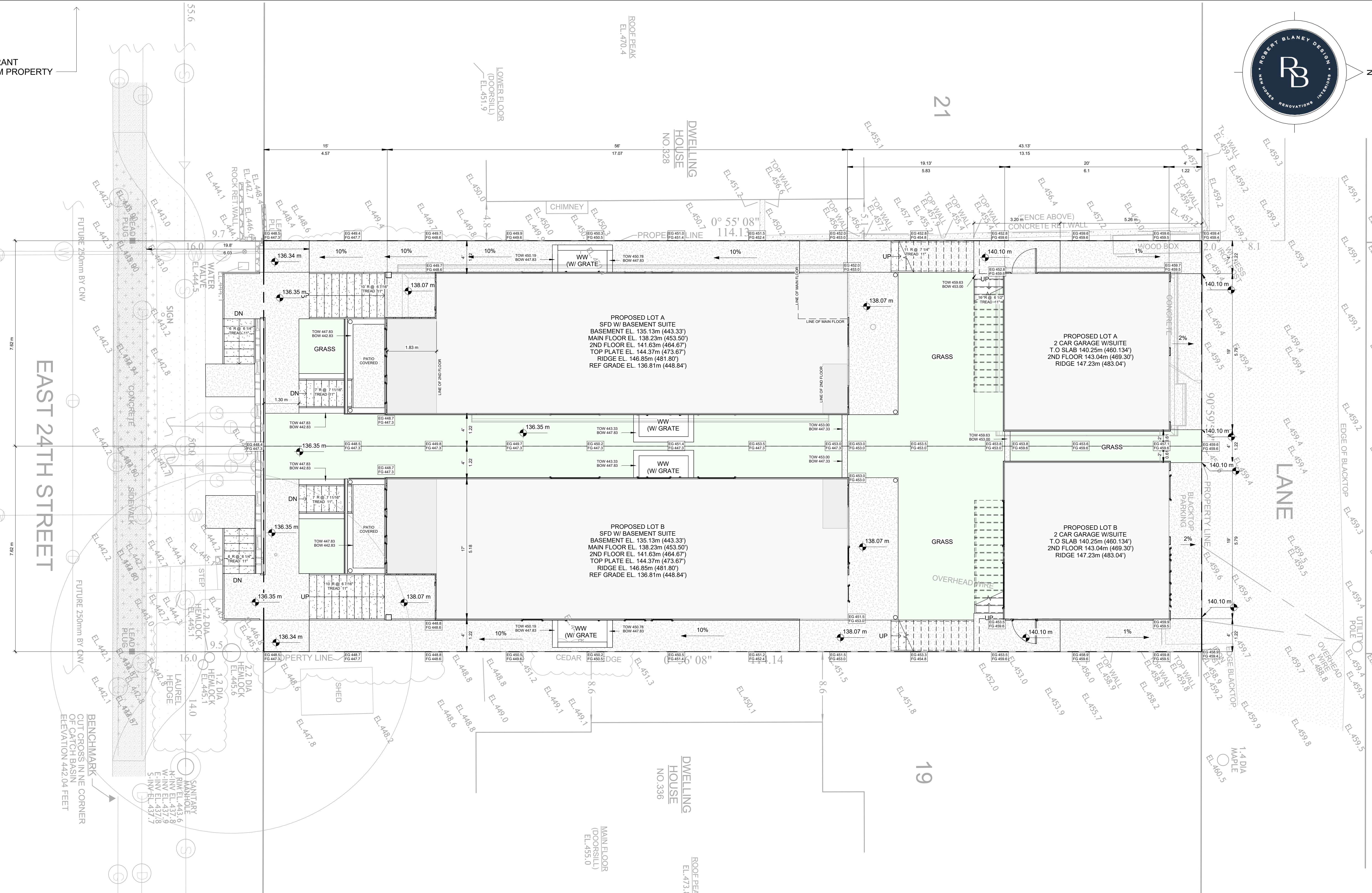

EAST 24TH STREET

EAST 24TH LANE



5464 PATRICIA BAY HIGHWAY,
VICTORIA BC V8Y 2N9

(604) 626-6020
ROBERTBLANEYDESIGN@GMAIL.COM
WWW.ROBERTBLANEYDESIGN.COM

REVISIONS
ISSUED FOR: IFR
REVIEW SET: 2024-06-26 3:03:23 PM

PROJECT:
LOT A & B
332 E 24TH
NORTH VANCOUVER

SHEET:

A100

DRAWN BY:
JP

24X36 SCALE: 1:64
PROJECT NUMBER: 038821

START DATE: 05.27.24

COPYRIGHT RESERVED.
THIS DRAWING AND DESIGN ARE AND SHALL AT ALL TIMES REMAIN THE EXCLUSIVE PROPERTY OF ROBERT BLANEY DESIGN AND CANNOT BE USED OR REPRODUCED WITHOUT WRITTEN CONSENT. WRITTEN DIMENSIONS SHALL HAVE PRECEDENCE OVER SCALED DIMENSIONS. CONTRACTOR SHALL VERIFY AND SHALL BE RESPONSIBLE FOR ALL DIMENSIONS AND CONDITIONS ON THE JOB AND THIS OFFICE SHALL BE INFORMED OF ANY VARIATIONS FROM THE DIMENSIONS AND CONDITIONS AS SHOWN ON THIS DRAWING. CONTRACTORS SHALL ENSURE THAT ALL CONSTRUCTION WILL COMPLY TO ALL APPLICABLE BUILDING CODES. ROBERT BLANEY DESIGN WILL NOT ACCEPT RESPONSIBILITY FOR VARIATIONS OR MODIFICATION OF THESE PLANS.

DRAWING TITLE:
SITE PLAN

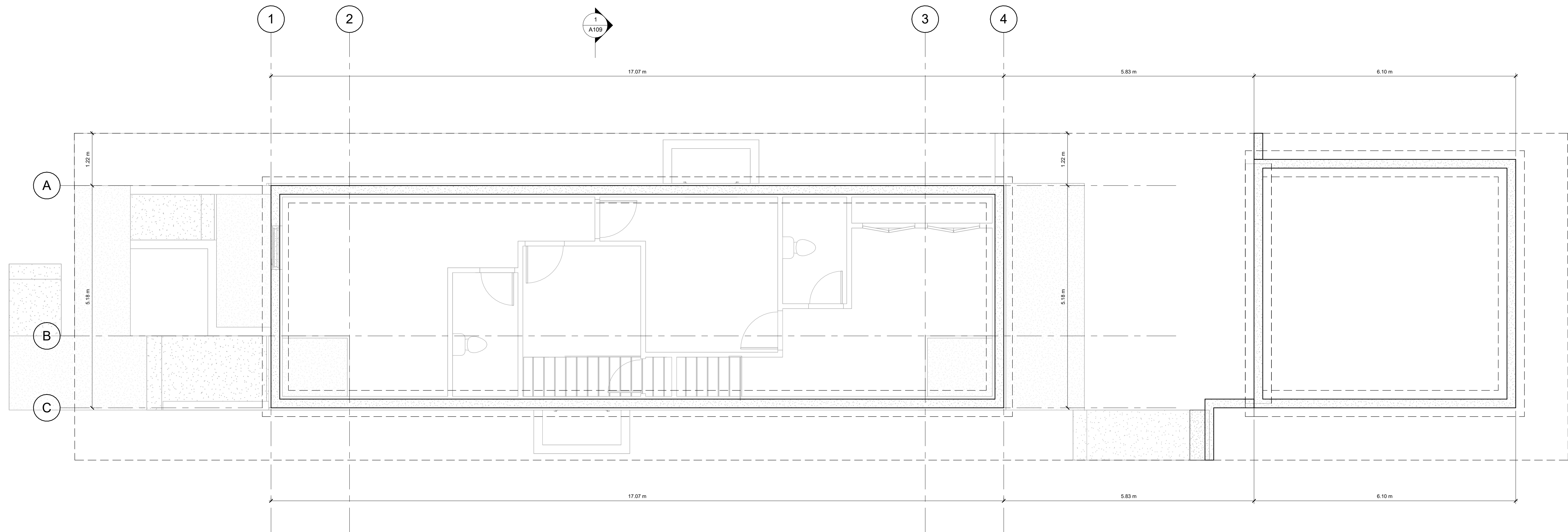
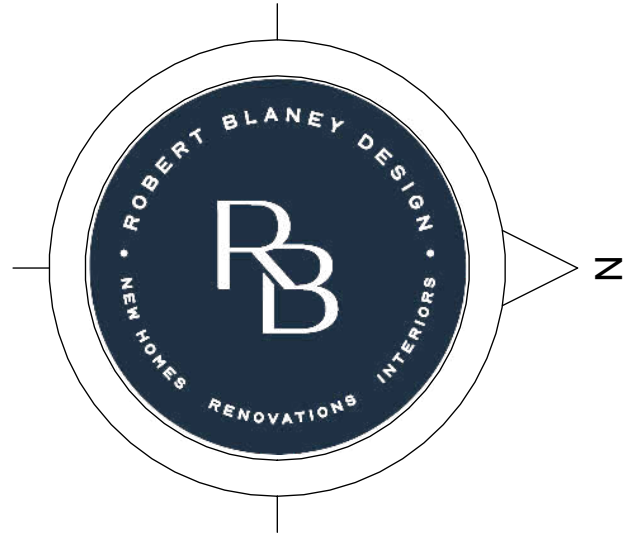

5464 PATRICIA BAY HIGHWAY,
VICTORIA BC V8Y 2N9

(604) 626-6020
ROBERTBLANEYDESIGN@GMAIL.COM
WWW.ROBERTBLANEYDESIGN.COM

REVISIONS
ISSUED FOR: IFR
REVIEW SET: 2024-06-26 3:08:45 PM

PROJECT:
LOT B
332 E 24TH
NORTH VANCOUVER

DRAWING TITLE:
FOUNDATION

SHEET:

A101

DRAWN BY:
JP

24X36 SCALE:
1 : 48

START DATE:
05.27.24

PROJECT NUMBER:
038821

COPYRIGHT RESERVED.

THIS DRAWING AND DESIGN ARE AND SHALL AT ALL TIMES REMAIN THE EXCLUSIVE PROPERTY OF ROBERT BLANEY DESIGN AND CANNOT BE USED OR REPRODUCED WITHOUT WRITTEN CONSENT. WRITTEN DIMENSIONS SHALL HAVE PRECEDENCE OVER SCALED DIMENSIONS. CONTRACTOR SHALL VERIFY AND SHALL BE RESPONSIBLE FOR ALL DIMENSIONS AND CONDITIONS ON THE JOB AND THIS OFFICE SHALL BE INFORMED OF ANY VARIATIONS FROM THE DIMENSIONS AND CONDITIONS AS SHOWN ON THIS DRAWING. CONTRACTORS SHALL ENSURE THAT ALL CONSTRUCTION WILL COMPLY TO ALL APPLICABLE BUILDING CODES. ROBERT BLANEY DESIGN WILL NOT ACCEPT RESPONSIBILITY FOR VARIATIONS OR MODIFICATION OF THESE PLANS.

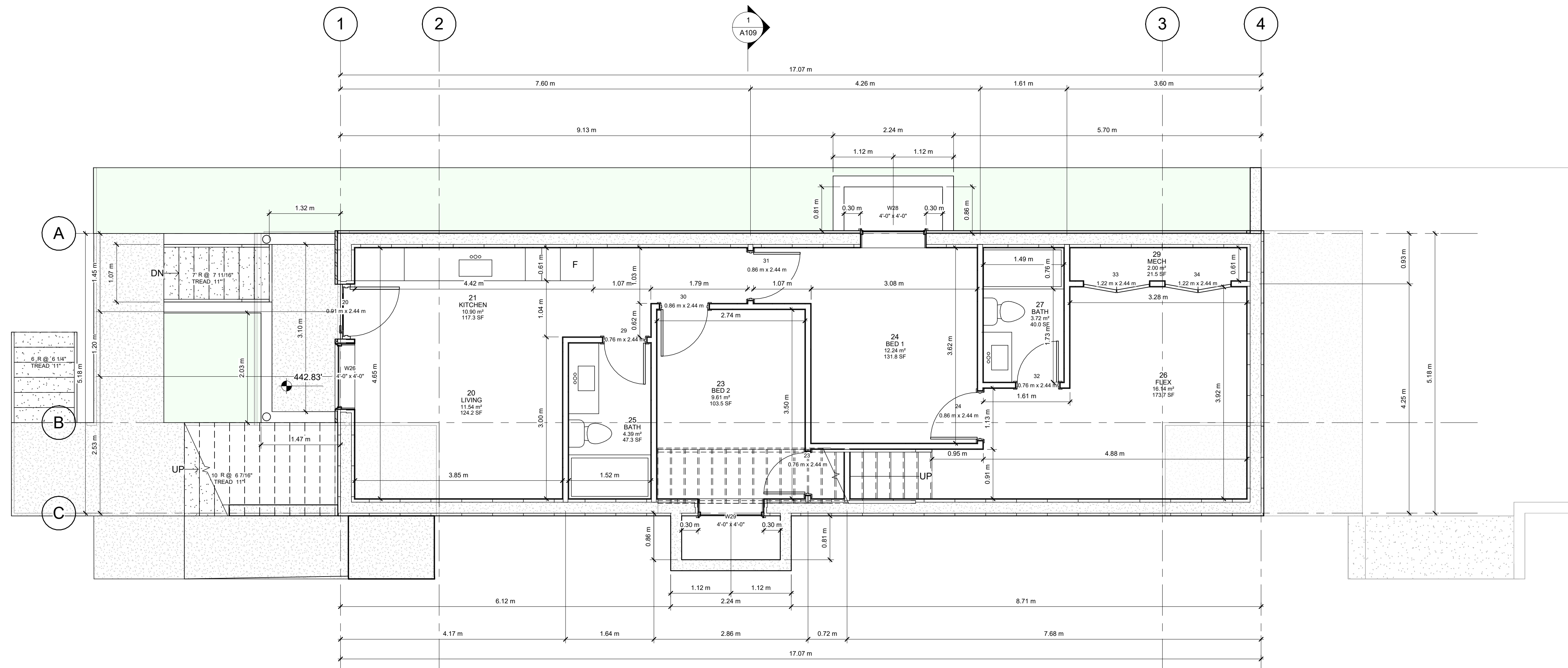

5464 PATRICIA BAY HIGHWAY,
VICTORIA BC V8Y 2N9

(604) 626-6020
ROBERTBLANEYDESIGN@GMAIL.COM
WWW.ROBERTBLANEYDESIGN.COM

REVISIONS
ISSUED FOR: IFR
REVIEW SET: 2024-06-26 3:08:46 PM

PROJECT:
LOT B
332 E 24TH
NORTH VANCOUVER

DRAWING TITLE:
BASEMENT FLOOR PLAN

SHEET:

A102

DRAWN BY:
JP

24X36 SCALE:
1:48

START DATE:
05.27.24

PROJECT NUMBER:
038821

COPYRIGHT RESERVED.
THIS DRAWING AND DESIGN ARE AND SHALL AT ALL TIMES REMAIN THE EXCLUSIVE PROPERTY OF ROBERT BLANEY DESIGN AND CANNOT BE USED OR REPRODUCED WITHOUT WRITTEN CONSENT. WRITTEN DIMENSIONS SHALL HAVE PRECEDENCE OVER SCALED DIMENSIONS. CONTRACTOR SHALL VERIFY AND SHALL BE RESPONSIBLE FOR ALL DIMENSIONS AND CONDITIONS ON THE JOB AND THIS OFFICE SHALL BE INFORMED OF ANY VARIATIONS FROM THE DIMENSIONS AND CONDITIONS AS SHOWN ON THIS DRAWING. CONTRACTORS SHALL ENSURE THAT ALL CONSTRUCTION WILL COMPLY TO ALL APPLICABLE BUILDING CODES. ROBERT BLANEY DESIGN WILL NOT ACCEPT RESPONSIBILITY FOR VARIATIONS OR MODIFICATION OF THESE PLANS.

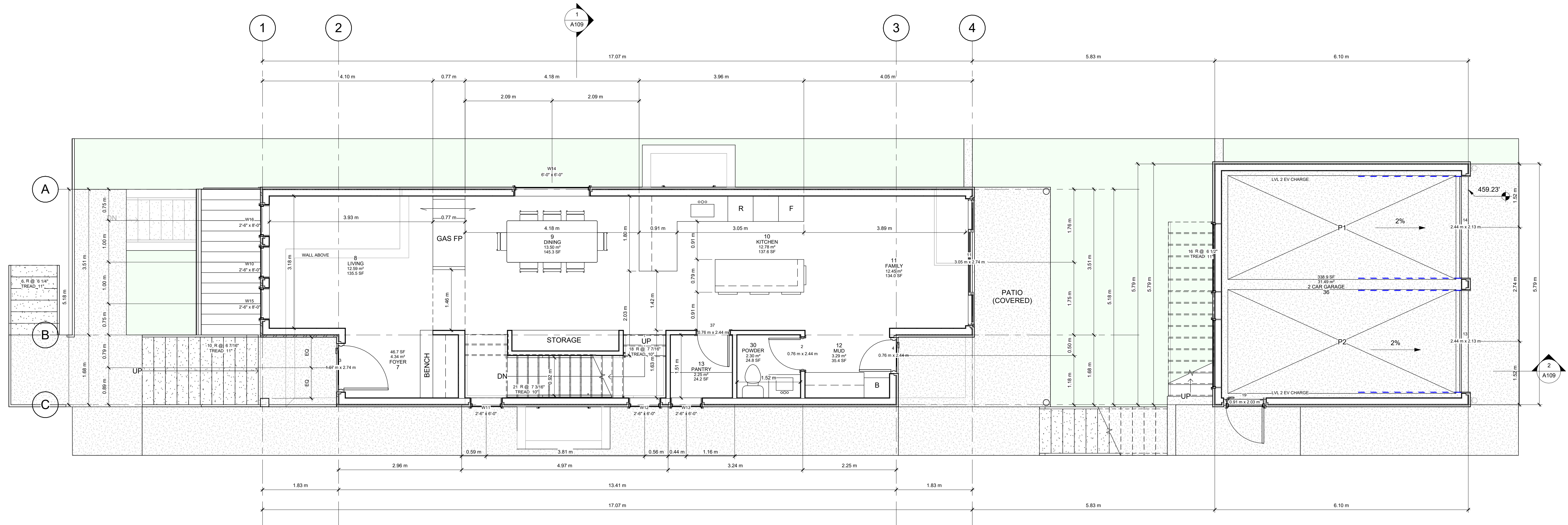

5464 PATRICIA BAY HIGHWAY,
VICTORIA BC V8Y 2N9

(604) 626-6020
ROBERTBLANEYDESIGN@GMAIL.COM
WWW.ROBERTBLANEYDESIGN.COM

REVISIONS
ISSUED FOR: IFR
REVIEW SET: 2024-06-26 3:08:46 PM

PROJECT:
LOT B
332 E 24TH
NORTH VANCOUVER

DRAWING TITLE:
MAIN FLOOR PLAN

SHEET:

A103

DRAWN BY:
JP

24X36 SCALE:
1/4" = 1'-0"

START DATE:
05.27.24

PROJECT NUMBER:
038821

COPYRIGHT RESERVED.

THIS DRAWING AND DESIGN ARE AND SHALL AT ALL TIMES REMAIN THE EXCLUSIVE PROPERTY OF ROBERT BLANEY DESIGN AND CANNOT BE USED OR REPRODUCED WITHOUT WRITTEN CONSENT. WRITTEN DIMENSIONS SHALL HAVE PRECEDENCE OVER SCALED DIMENSIONS. CONTRACTOR SHALL VERIFY AND SHALL BE RESPONSIBLE FOR ALL DIMENSIONS AND CONDITIONS ON THE JOB AND THIS OFFICE SHALL BE INFORMED OF ANY VARIATIONS FROM THE DIMENSIONS AND CONDITIONS AS SHOWN ON THIS DRAWING. CONTRACTORS SHALL ENSURE THAT ALL CONSTRUCTION WILL COMPLY TO ALL APPLICABLE BUILDING CODES. ROBERT BLANEY DESIGN WILL NOT ACCEPT RESPONSIBILITY FOR VARIATIONS OR MODIFICATION OF THESE PLANS.

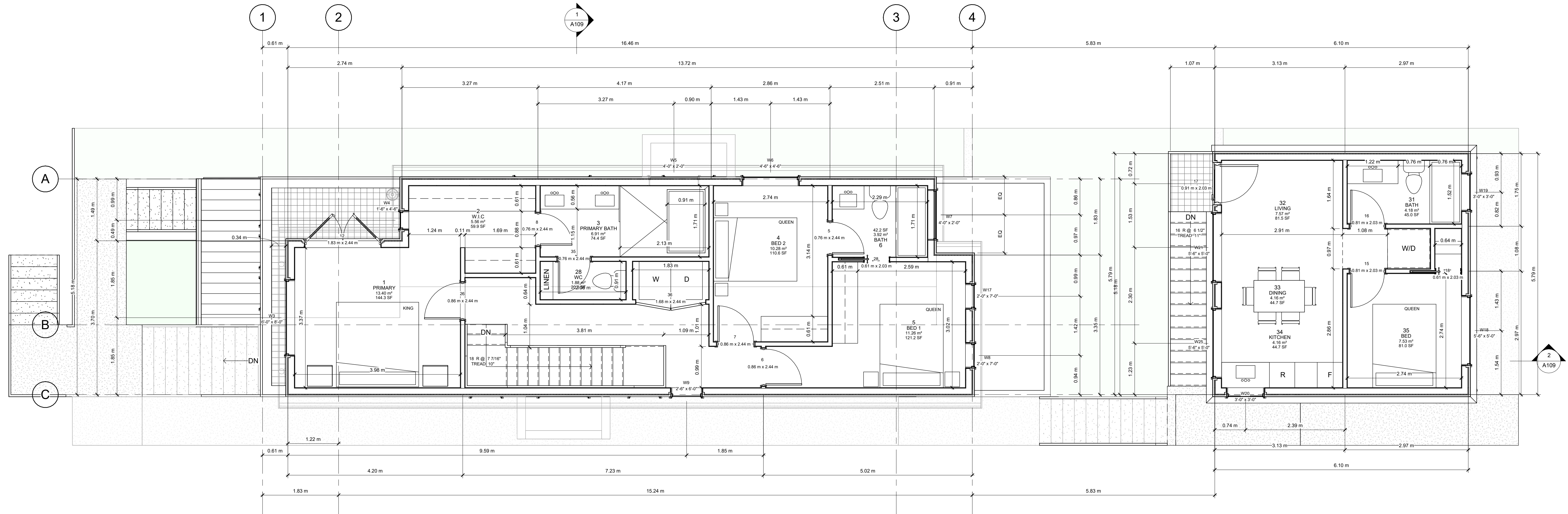
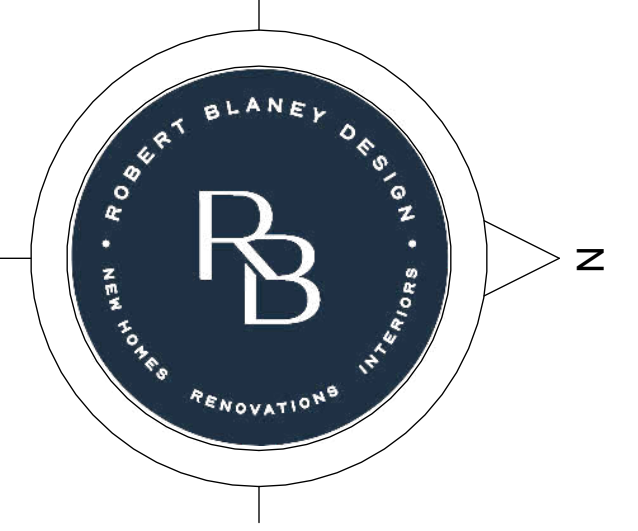

5464 PATRICIA BAY HIGHWAY,
VICTORIA BC V8Y 2N9

(604) 626-6020
ROBERTBLANEYDESIGN@GMAIL.COM
WWW.ROBERTBLANEYDESIGN.COM

REVISIONS
ISSUED FOR: IFR
REVIEW SET: 2024-06-26 3:08:47 PM

PROJECT:
LOT B
332 E 24TH
NORTH VANCOUVER

DRAWING TITLE:
2ND FLOOR PLAN

SHEET:

A104

DRAWN BY:
JP

24X36 SCALE:
1 : 48

START DATE:
05.27.24

PROJECT NUMBER:
038821

COPYRIGHT RESERVED.

THIS DRAWING AND DESIGN ARE AND SHALL AT ALL TIMES REMAIN THE EXCLUSIVE PROPERTY OF ROBERT BLANEY DESIGN AND CANNOT BE USED OR REPRODUCED WITHOUT WRITTEN CONSENT. WRITTEN DIMENSIONS SHALL HAVE PRECEDENCE OVER SCALED DIMENSIONS. CONTRACTOR SHALL VERIFY AND SHALL BE RESPONSIBLE FOR ALL DIMENSIONS AND CONDITIONS ON THE JOB AND THIS OFFICE SHALL BE INFORMED OF ANY VARIATIONS FROM THE DIMENSIONS AND CONDITIONS AS SHOWN ON THIS DRAWING. CONTRACTORS SHALL ENSURE THAT ALL CONSTRUCTION WILL COMPLY TO ALL APPLICABLE BUILDING CODES. ROBERT BLANEY DESIGN WILL NOT ACCEPT RESPONSIBILITY FOR VARIATIONS OR MODIFICATION OF THESE PLANS.

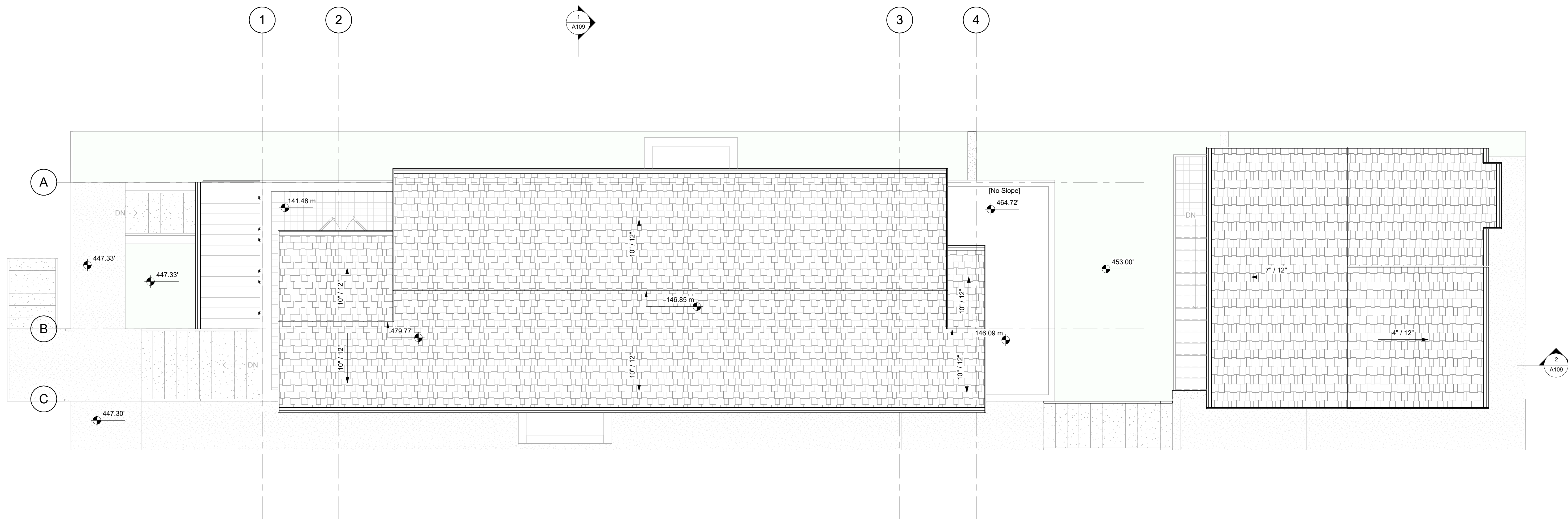
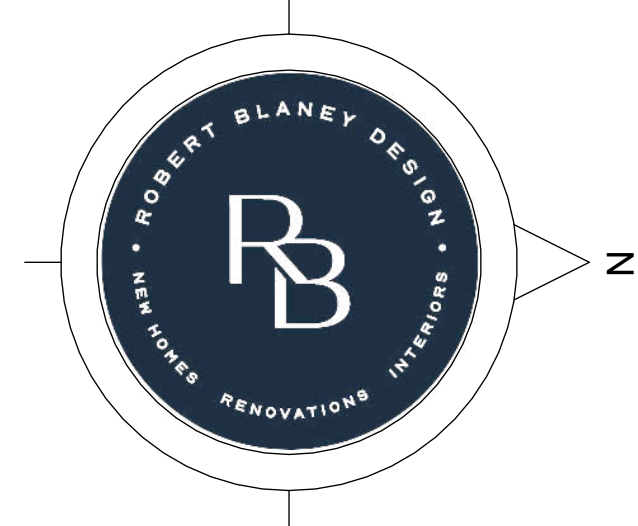

5464 PATRICIA BAY HIGHWAY,
VICTORIA BC V8Y 2N9

(604) 626-6020
ROBERTBLANEYDESIGN@GMAIL.COM
WWW.ROBERTBLANEYDESIGN.COM

REVISIONS
ISSUED FOR: IFR
REVIEW SET: 2024-06-26 3:08:48 PM

PROJECT:
LOT B
332 E 24TH
NORTH VANCOUVER

DRAWING TITLE:
ROOF PLAN

SHEET:

A105

DRAWN BY:

JP

24X36 SCALE:

1/4" = 1'-0"

PROJECT NUMBER:

038821

START DATE:

05.27.24

COPYRIGHT RESERVED.

THIS DRAWING AND DESIGN ARE AND SHALL AT ALL TIMES REMAIN THE EXCLUSIVE PROPERTY OF ROBERT BLANEY DESIGN AND CANNOT BE USED OR REPRODUCED WITHOUT WRITTEN CONSENT. WRITTEN DIMENSIONS SHALL HAVE PRECEDENCE OVER SCALED DIMENSIONS. CONTRACTOR SHALL VERIFY AND SHALL BE RESPONSIBLE FOR ALL DIMENSIONS AND CONDITIONS ON THE JOB AND THIS OFFICE SHALL BE INFORMED OF ANY VARIATIONS FROM THE DIMENSIONS AND CONDITIONS AS SHOWN ON THIS DRAWING. CONTRACTORS SHALL ENSURE THAT ALL CONSTRUCTION WILL COMPLY TO ALL APPLICABLE BUILDING CODES. ROBERT BLANEY DESIGN WILL NOT ACCEPT RESPONSIBILITY FOR VARIATIONS OR MODIFICATION OF THESE PLANS.



1 NORTH
1 : 48



2 SOUTH
1 : 48

LEGEND	
STUCCO (WHITE)	A
STONE (TBD)	B
ASPHALT SHINGLES	C
STANDING SEAM METAL	D



5464 PATRICIA BAY HIGHWAY,
VICTORIA BC V8Y 2N9

(604) 626-6020
ROBERTBLANEYDESIGN@GMAIL.COM
WWW.ROBERTBLANEYDESIGN.COM

REVISIONS
ISSUED FOR: IFR
REVIEW SET: 2024-06-26 3:08:54 PM

PROJECT:
LOT B
332 E 24TH
NORTH VANCOUVER

DRAWING TITLE:
ELEVATIONS - NORTH &
SOUTH

SHEET:
A106

DRAWN BY:
JP

24X36 SCALE: 1 : 48
PROJECT NUMBER: 038821

START DATE: 05.27.24

COPYRIGHT RESERVED.
THIS DRAWING AND DESIGN ARE AND SHALL AT ALL TIMES REMAIN THE EXCLUSIVE PROPERTY OF ROBERT BLANEY DESIGN AND CANNOT BE USED OR REPRODUCED WITHOUT WRITTEN CONSENT. WRITTEN DIMENSIONS SHALL HAVE PRECEDENCE OVER SCALED DIMENSIONS. CONTRACTOR SHALL VERIFY AND SHALL BE RESPONSIBLE FOR ALL DIMENSIONS AND CONDITIONS ON THE JOB AND THIS OFFICE SHALL BE INFORMED OF ANY VARIATIONS FROM THE DIMENSIONS AND CONDITIONS AS SHOWN ON THIS DRAWING. CONTRACTORS SHALL ENSURE THAT ALL CONSTRUCTION WILL COMPLY TO ALL APPLICABLE BUILDING CODES. ROBERT BLANEY DESIGN WILL NOT ACCEPT RESPONSIBILITY FOR VARIATIONS OR MODIFICATION OF THESE PLANS.

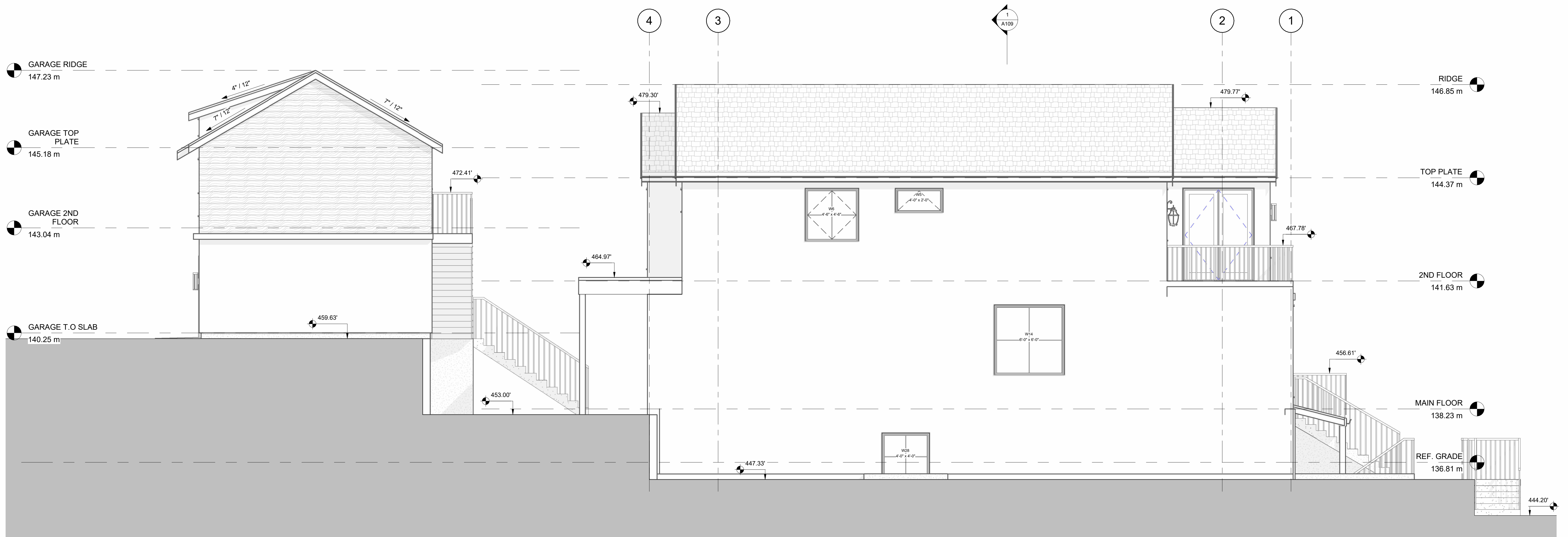

2 EAST
1 : 48

LEGEND	
STUCCO (WHITE)	A
STONE (TBD)	B
ASPHALT SHINGLES	C
STANDING SEAM METAL	D



5464 PATRICIA BAY HIGHWAY,
VICTORIA BC V8Y 2N9

(604) 626-6020
ROBERTBLANEYDESIGN@GMAIL.COM
WWW.ROBERTBLANEYDESIGN.COM

REVISIONS
ISSUED FOR: IFR
REVIEW SET: 2024-06-26 3:09:01 PM

PROJECT:
LOT B
332 E 24TH
NORTH VANCOUVER

SHEET:

A107

DRAWN BY:
JP

24X36 SCALE:
1/4" = 1'-0"

START DATE:
05.27.24

PROJECT NUMBER:
038821

DRAWING TITLE:
ELEVATIONS - EAST

COPYRIGHT RESERVED.
THIS DRAWING AND DESIGN ARE AND SHALL AT ALL TIMES REMAIN THE EXCLUSIVE PROPERTY OF ROBERT BLANEY DESIGN AND CANNOT BE USED OR REPRODUCED WITHOUT WRITTEN CONSENT. WRITTEN DIMENSIONS SHALL HAVE PRECEDENCE OVER SCALED DIMENSIONS. CONTRACTOR SHALL VERIFY AND SHALL BE RESPONSIBLE FOR ALL DIMENSIONS AND CONDITIONS ON THE JOB AND THIS OFFICE SHALL BE INFORMED OF ANY VARIATIONS FROM THE DIMENSIONS AND CONDITIONS AS SHOWN ON THIS DRAWING. CONTRACTORS SHALL ENSURE THAT ALL CONSTRUCTION WILL COMPLY TO ALL APPLICABLE BUILDING CODES. ROBERT BLANEY DESIGN WILL NOT ACCEPT RESPONSIBILITY FOR VARIATIONS OR MODIFICATION OF THESE PLANS.

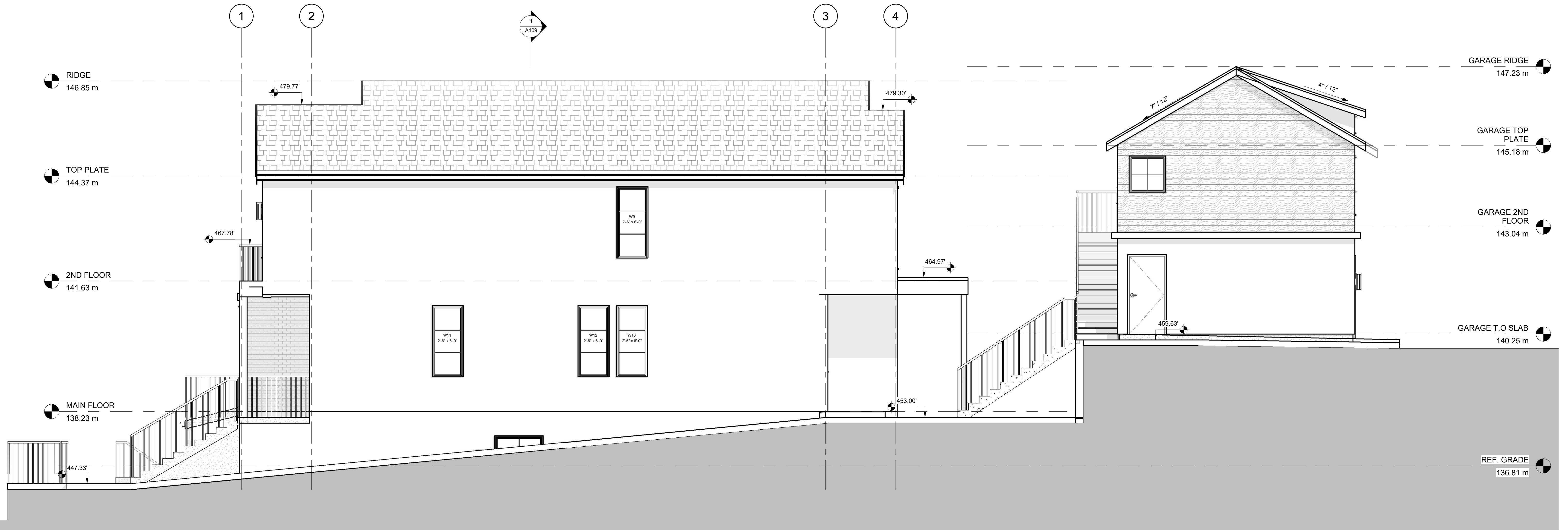

1 WEST
1 : 48

LEGEND	
STUCCO (WHITE)	A
STONE (TBD)	B
ASPHALT SHINGLES	C
STANDING SEAM METAL	D



5464 PATRICIA BAY HIGHWAY,
VICTORIA BC V8Y 2N9

(604) 626-6020
ROBERTBLANEYDESIGN@GMAIL.COM
WWW.ROBERTBLANEYDESIGN.COM

REVISIONS
ISSUED FOR: IFR
REVIEW SET: 2024-06-26 3:09:07 PM

PROJECT:
LOT B
332 E 24TH
NORTH VANCOUVER

SHEET:
A108

DRAWN BY:
JP

24X36 SCALE: 1/4" = 1'-0"
PROJECT NUMBER: 038821

START DATE: 05.27.24

COPYRIGHT RESERVED.
THIS DRAWING AND DESIGN ARE AND SHALL AT ALL TIMES REMAIN THE EXCLUSIVE PROPERTY OF ROBERT BLANEY DESIGN AND CANNOT BE USED OR REPRODUCED WITHOUT WRITTEN CONSENT. WRITTEN DIMENSIONS SHALL HAVE PRECEDENCE OVER SCALED DIMENSIONS. CONTRACTOR SHALL VERIFY AND SHALL BE RESPONSIBLE FOR ALL DIMENSIONS AND CONDITIONS ON THE JOB AND THIS OFFICE SHALL BE INFORMED OF ANY VARIATIONS FROM THE DIMENSIONS AND CONDITIONS AS SHOWN ON THIS DRAWING. CONTRACTORS SHALL ENSURE THAT ALL CONSTRUCTION WILL COMPLY TO ALL APPLICABLE BUILDING CODES. ROBERT BLANEY DESIGN WILL NOT ACCEPT RESPONSIBILITY FOR VARIATIONS OR MODIFICATION OF THESE PLANS.

DRAWING TITLE:
ELEVATIONS - WEST



1 Section 1
1 : 48

R1 TRUSS ROOF

STANDING SEAM METAL
UNDERLAYMENT
3/4" ROOF SHAETHING
2X4" CROSS STRAPPING @ 24" O.C
ENGINEERED TRUSSES @ 24" O.C
BLOWN INSULATION (R50)
6MIL POLY V.B. TAPED AND SEALED
1/2" G.W.B PAINTED
AIR FILM (INTERIOR)

R2 FLAT ROOF

2 LAYERS TORCH ON ROOFING
3/4" ROOF SHAETHING
2X4" CROSS STRAPPING @ 16" O.C
11-7/8" TGI RAFTERS @ 16" O.C
BATT INSULATION (R28)
6MIL POLY V.B. TAPED AND SEALED
1/2" G.W.B PAINTED
AIR FILM (INTERIOR)

W1 EXTERIOR WALL (ABOVE GRADE)

CLADDING
1/2" PURLINS OR RAIN-SCREEN SYSTEM
TYVEK SEALED & TAPED
1/2" PLYWOOD SHEATHING
2X6" STUDS @ 16" O.C
BATT INSULATION (R22)
6MIL POLY V.B
1/2" G.W.B PAINTED
AIR FILM (INTERIOR)

W2 ICF FOUNDATION WALL

DRAINAGE MAT W/ FILTER FABRIC
2 COATS OF BITUMINOUS SEALANT
2" RIGID INSUL.
8" FOUNDATION WALL
2" RIGID INSUL.
6MIL POLY V.B.
1/2" G.W.B
AIR FILM (INTERIOR)

W3 ICF FOUNDATION WALL

DRAINAGE MAT W/ FILTER FABRIC
2 COATS OF BITUMINOUS SEALANT
2" RIGID INSUL.
8" FOUNDATION WALL
2" RIGID INSUL.

W4 INTERIOR WALL - 2x6"

1/2" G.W.B BOTH SIDES
2X6" STUDS @ 16" O.C

F1 FLOOR OVER CONDITIONED SPACE

FLOOR FINISH
1-1/2" CONCRETE TOPPING
3/4" T&G FLOOR SHEATHING GLUED & SCREWED
11-7/8" TJI JOISTS @ 12" O.C
1/2" G.W.B PAINTED

F2 FLOOR OVER UNCONDITIONED SPACE

FLOOR FINISH
1-1/2" CONCRETE TOPPING
3/4" T&G FLOOR SHEATHING GLUED & SCREWED
11-7/8" TJI JOISTS @ 16" O.C
SPRAY FOAM CLOSED CELL INSUL (R28)

F3 BASEMENT SLAB

FLOOR FINISH
4" REINFORCED CONCRETE SLAB
6MIL POLY V.B
3" RIGID INSULATION UNDER SLAB (R16)
6" MIN. COMPACTED GRANULAR BASE
RADON GAS VENTED

F4 PATIO SLAB/DRIVEWAY ON GRADE

4" REINFORCED CONCRETE SLAB
6" MIN. COMPACTED GRANULAR BASE

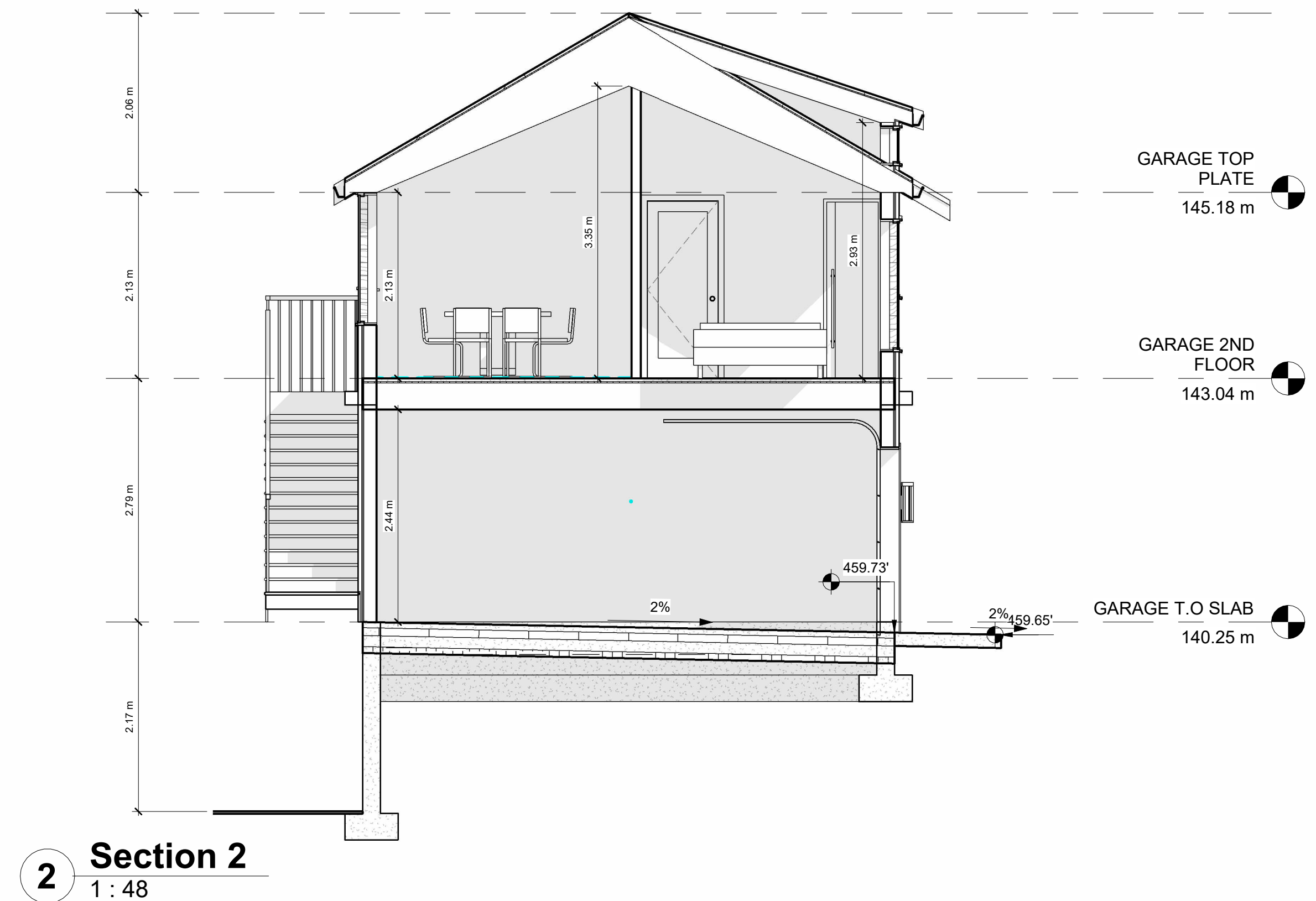

2 Section 2
1 : 48

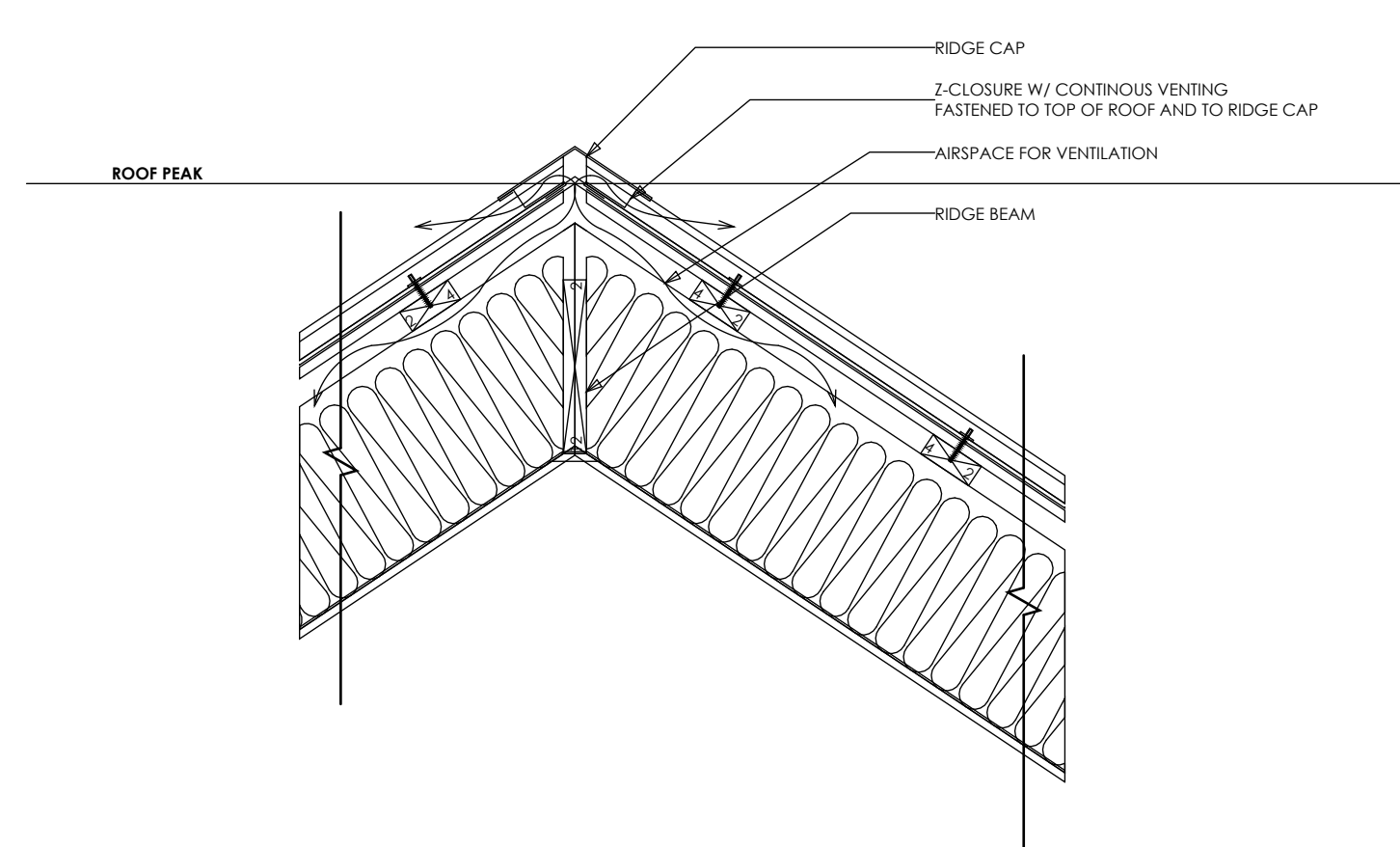

9 RIDGE VENTING - VAULT
1 : 12

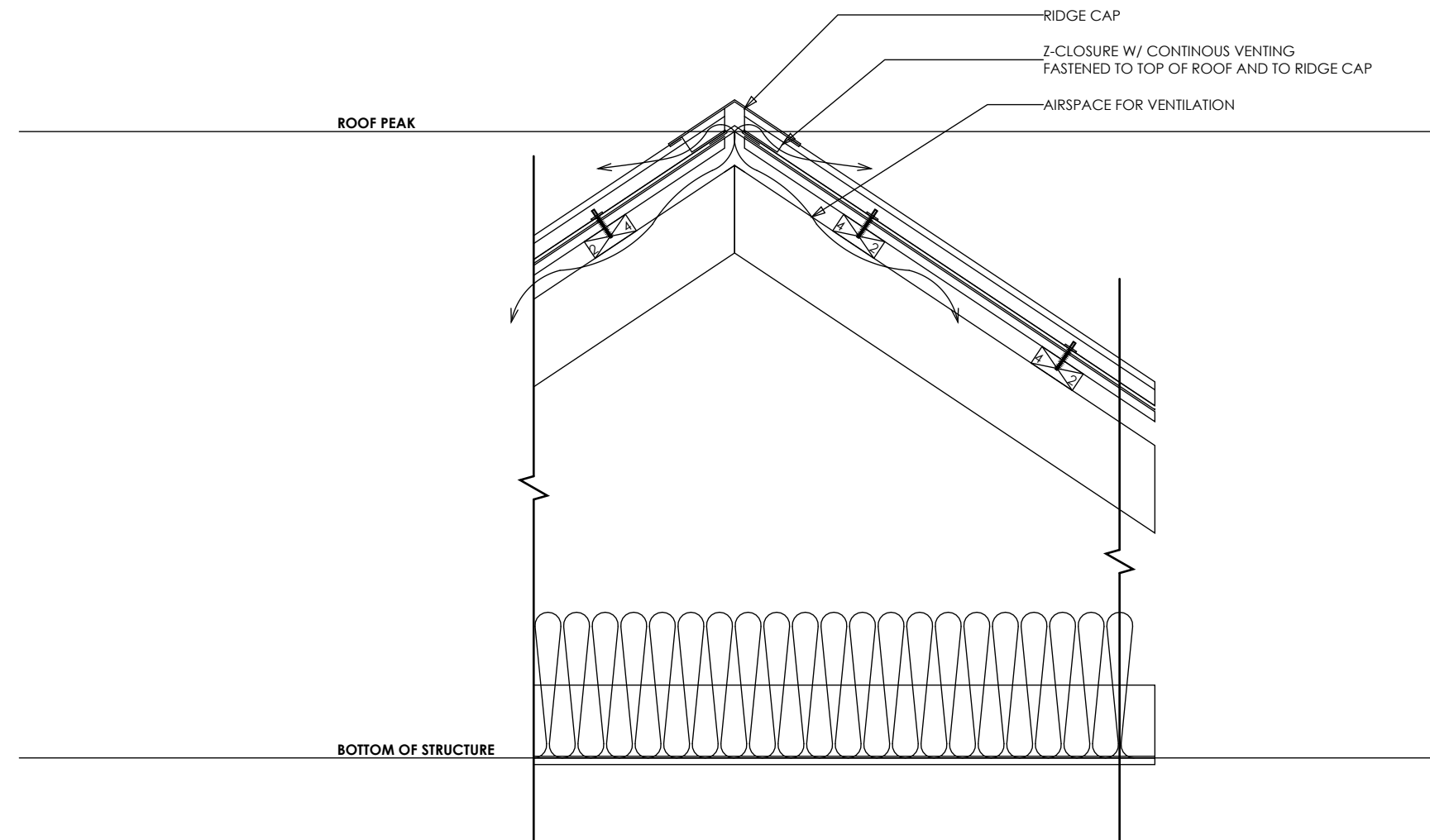

8 RIDGE VENTING - TRUSS
1 : 12

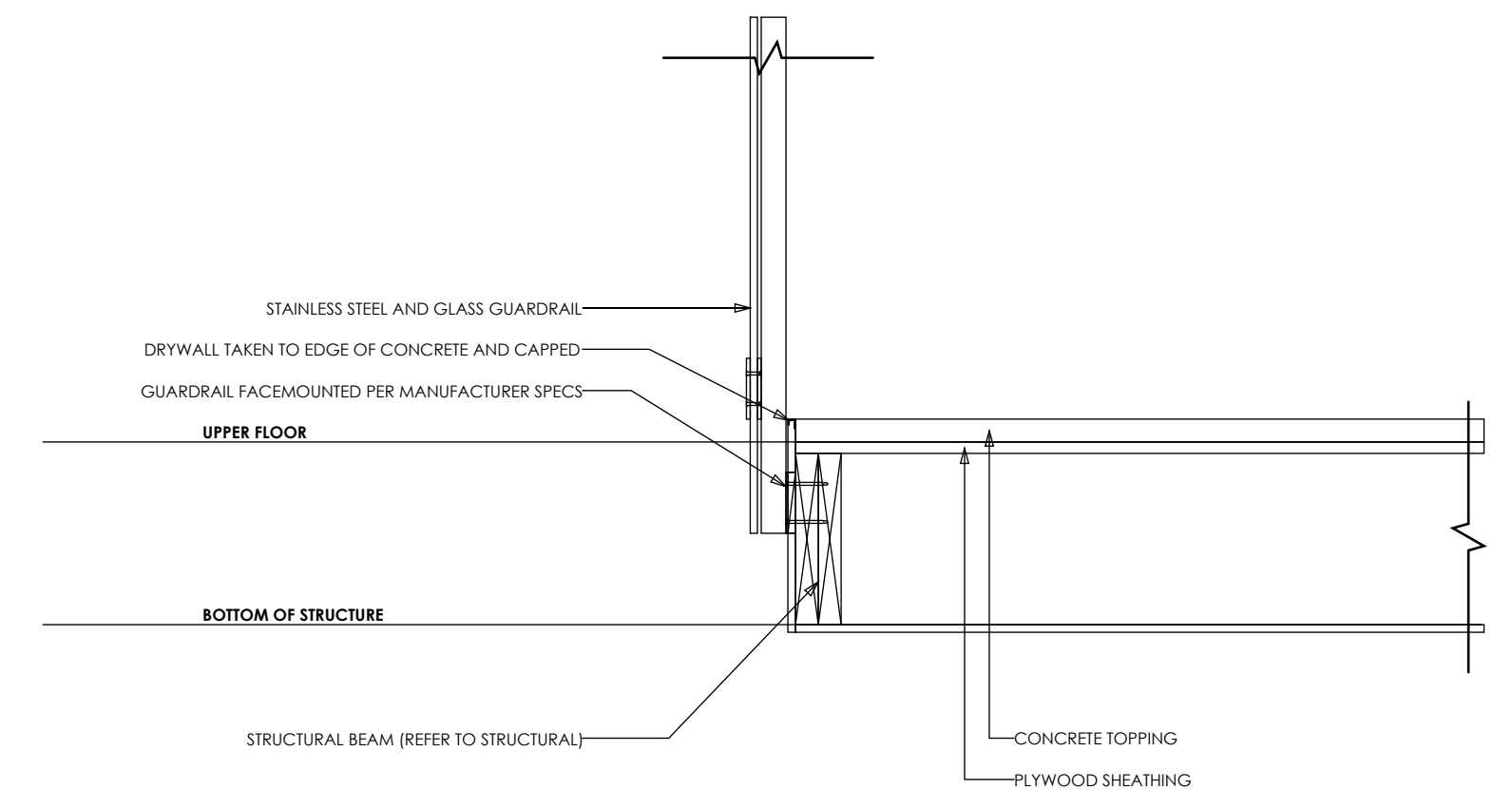

10 GUARDRAIL
1 : 12

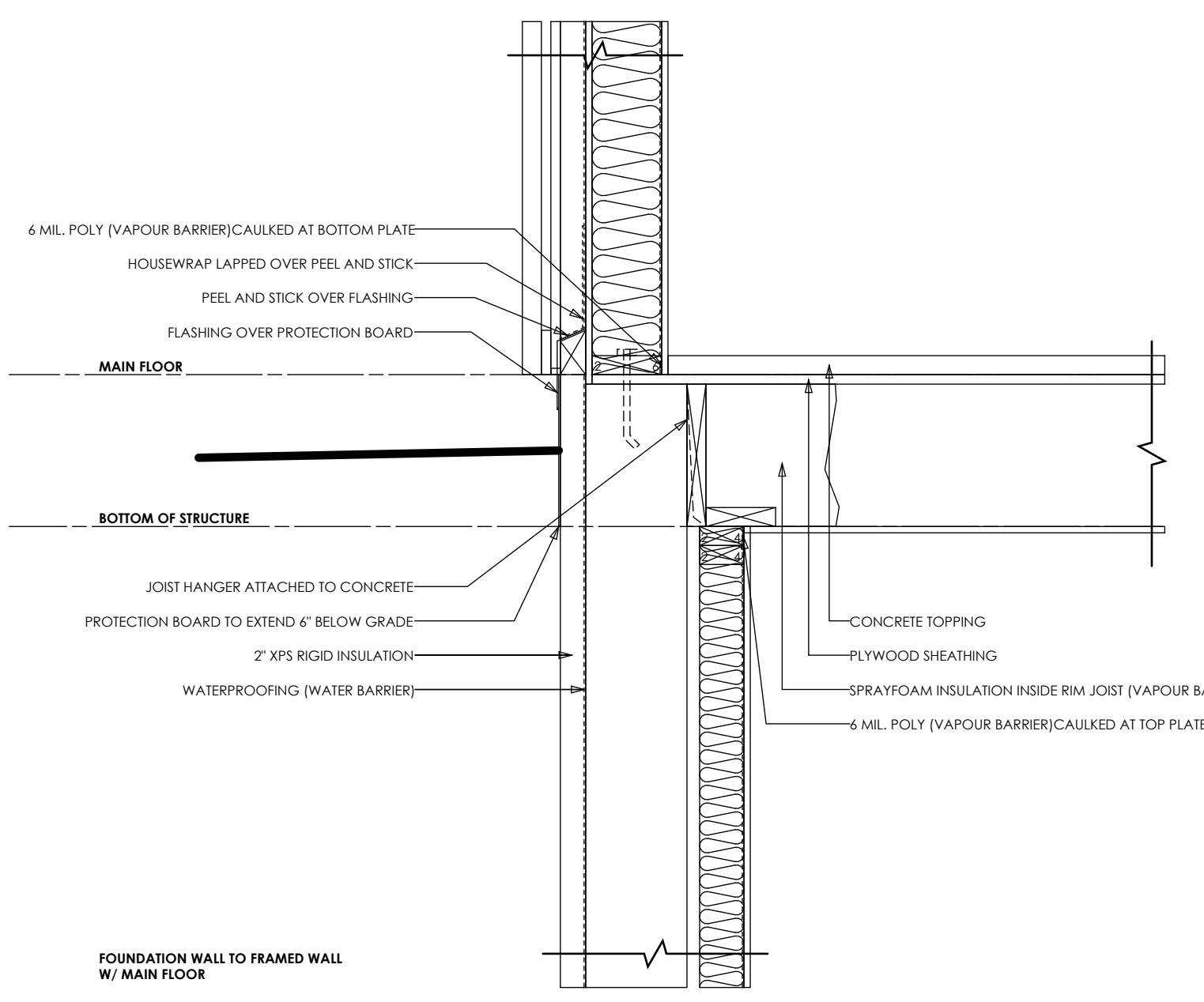

5 FOUNDATION TO MAIN
1 : 12

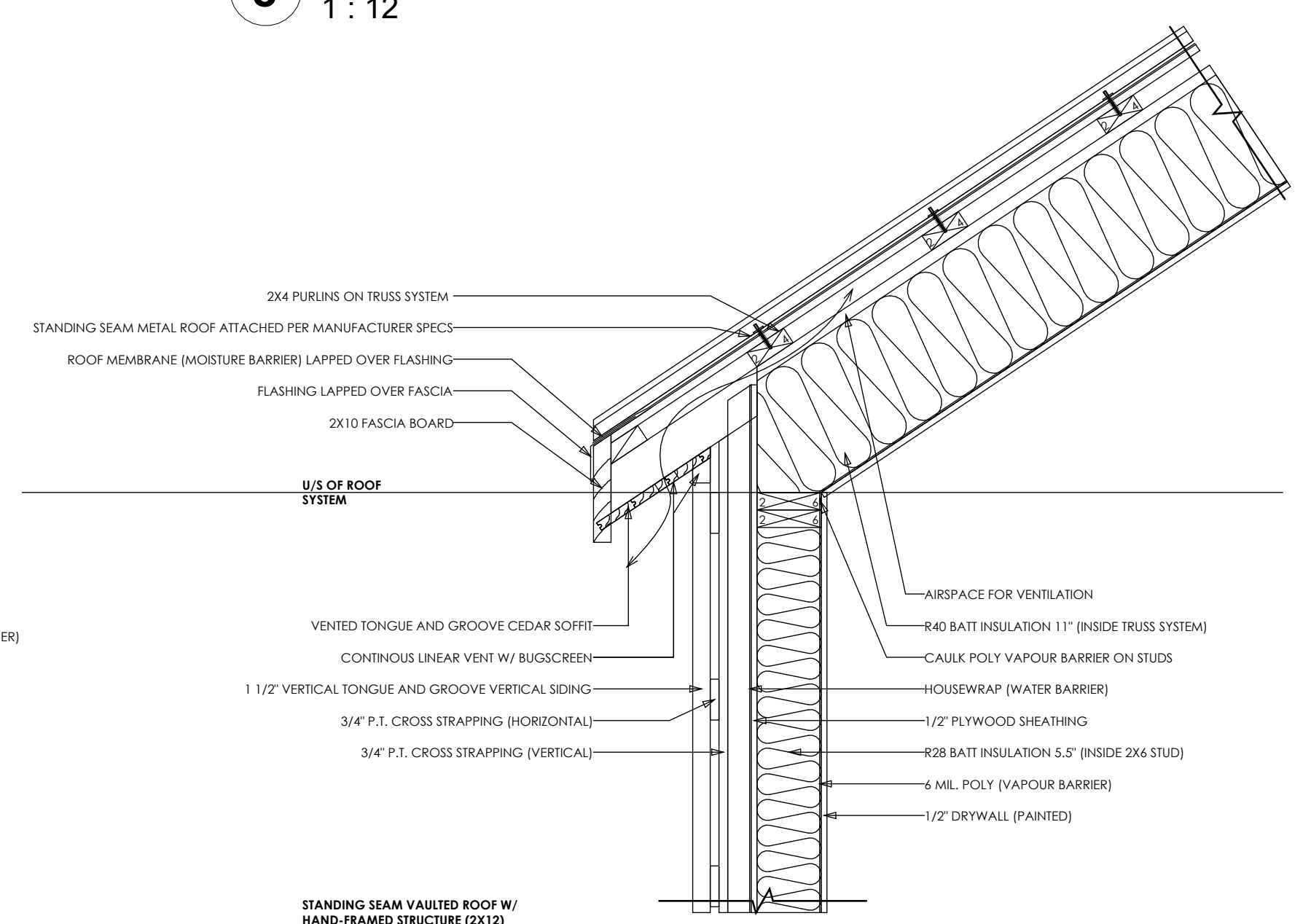

7 2ND TO ROOF
1 : 12

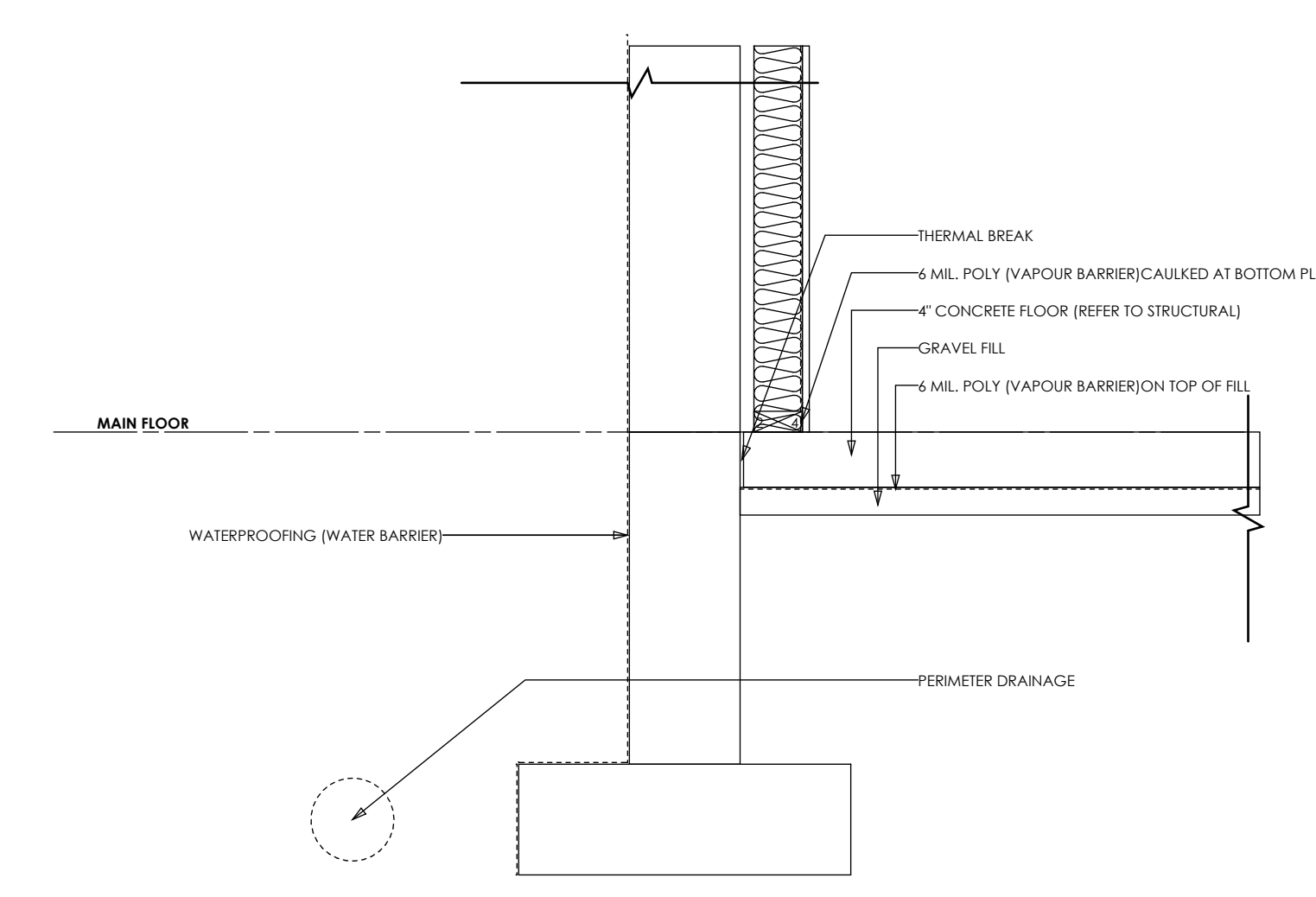

4 FOOTING TO FOUNDATION
1 : 12

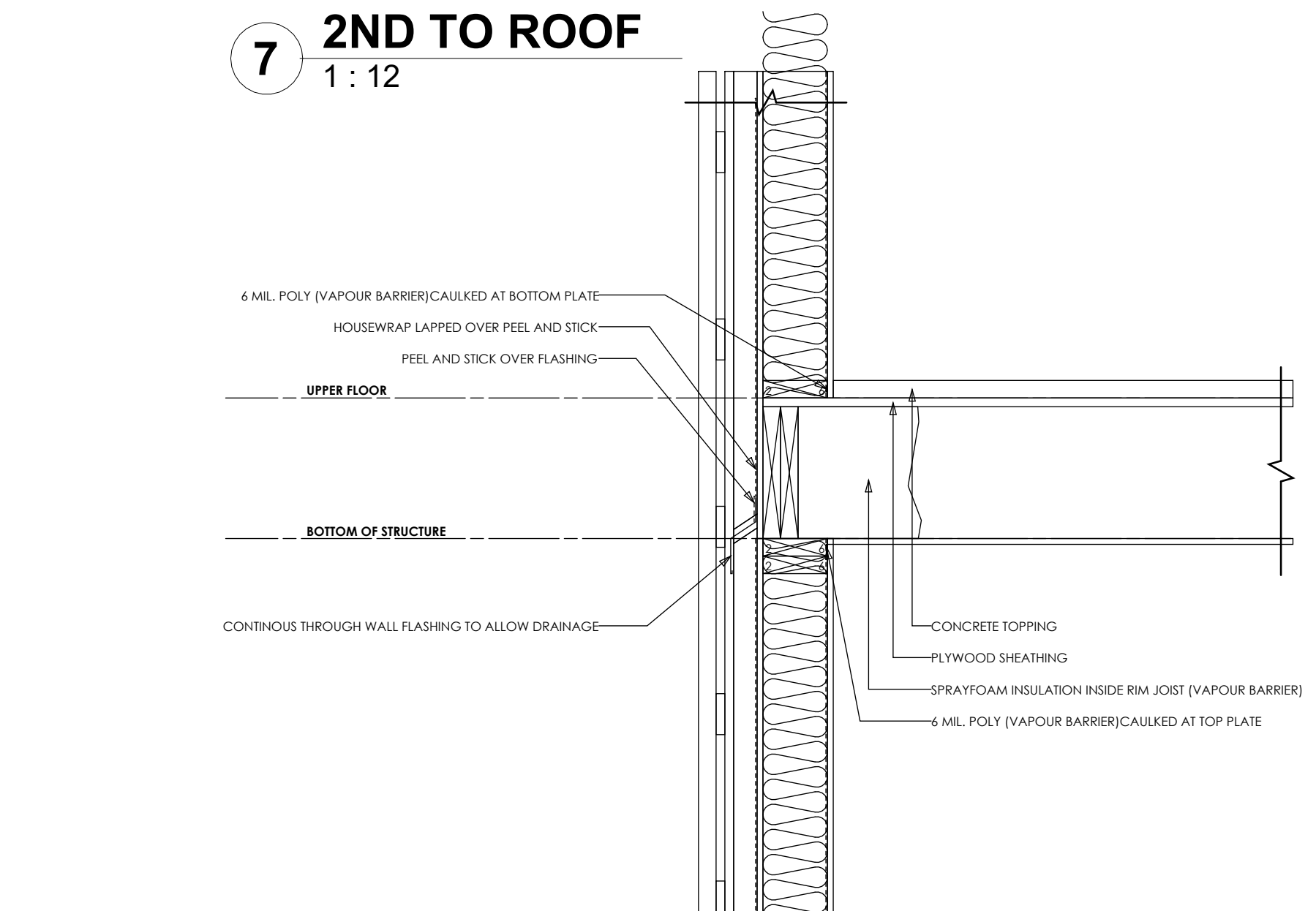

6 MAIN TO 2ND
1 : 12

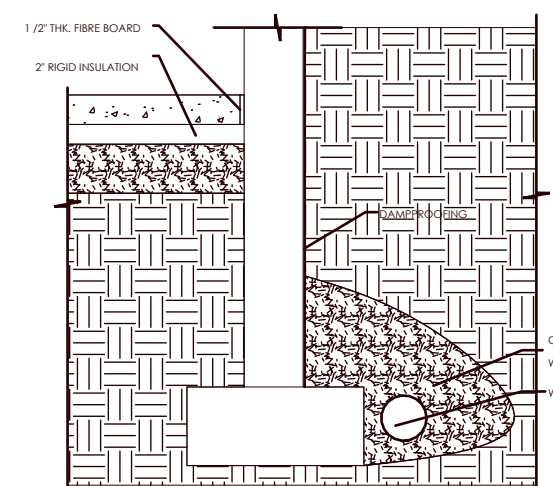

2 FOUNDATION

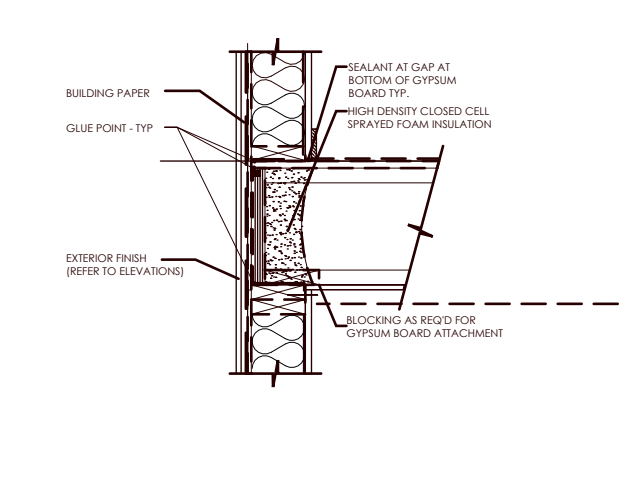

3 FLOOR JOIST

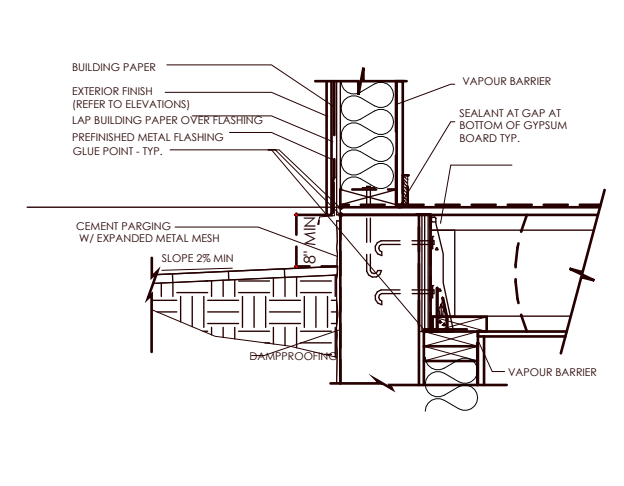

4 FLOOR JOIST

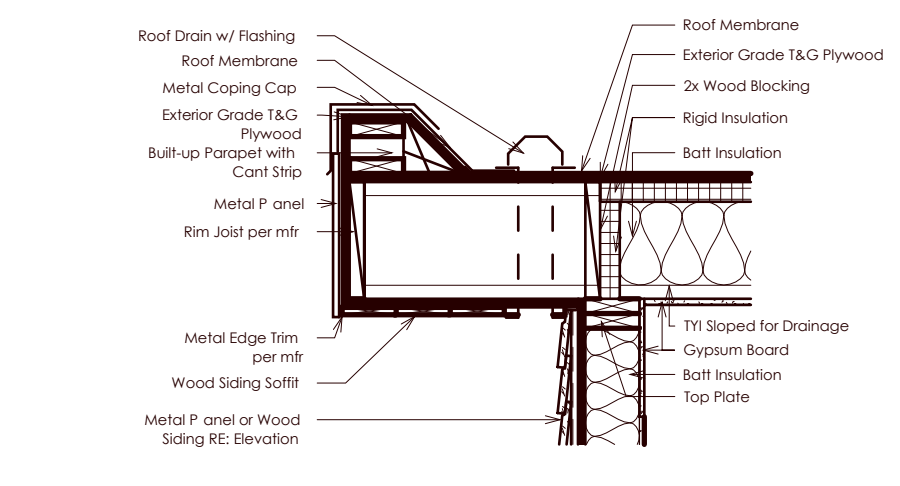

5 FLAT ROOF O.H

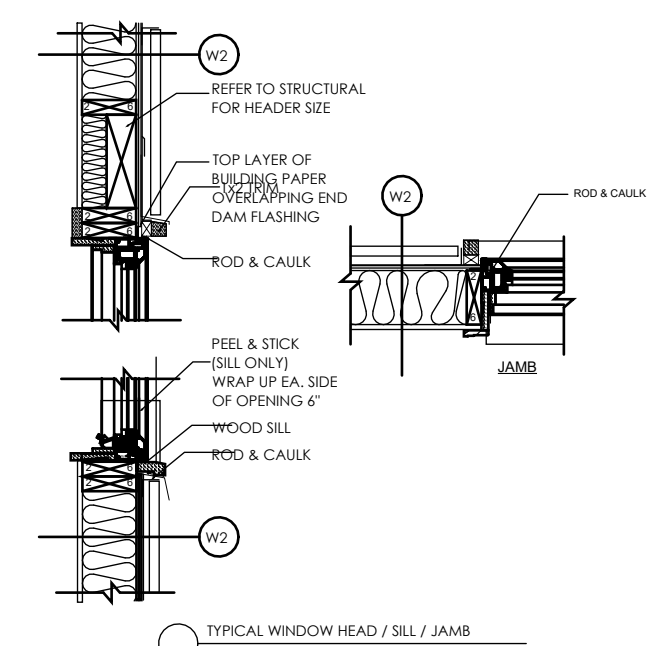

TYPICAL WINDOW HEAD / SILL / JAMB
SCALE 1" = 8"

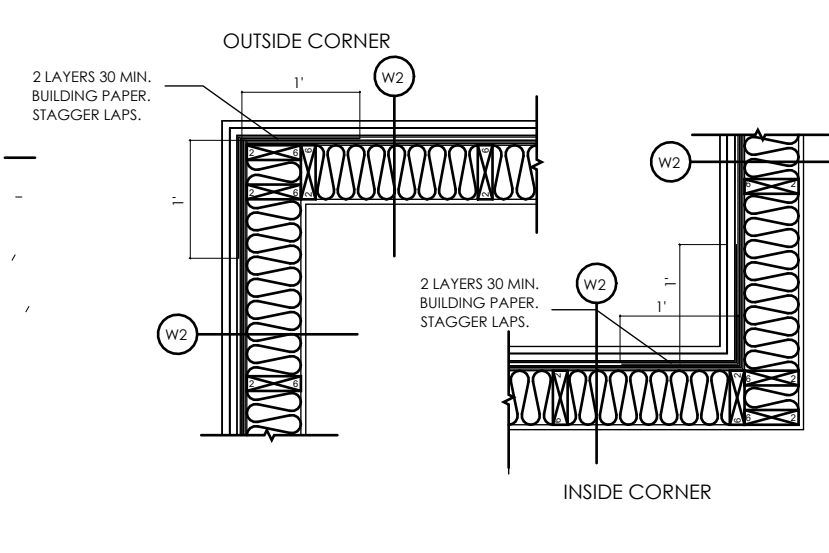

TYPICAL EXTERIOR WALL CONNECTION
SCALE 1" = 8"

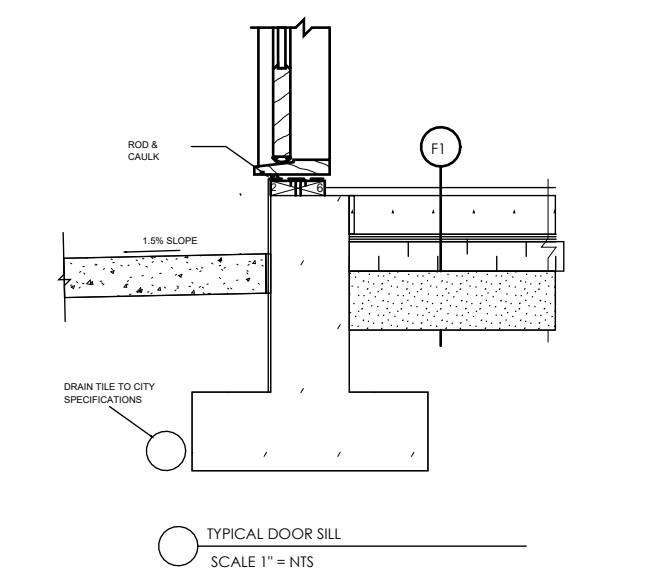

TYPICAL DOOR SILL
SCALE 1" = 8"

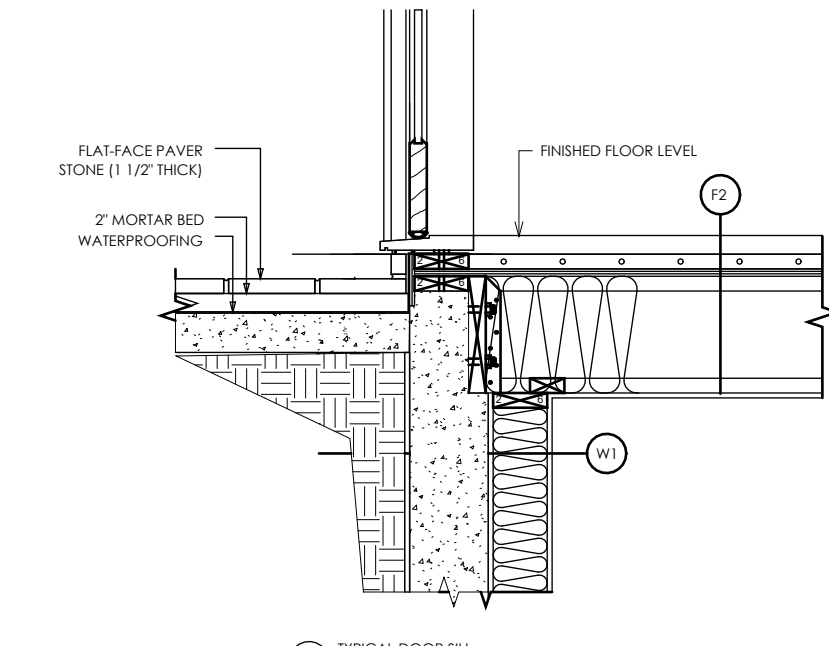

TYPICAL DOOR SILL
SCALE 1" = 8"

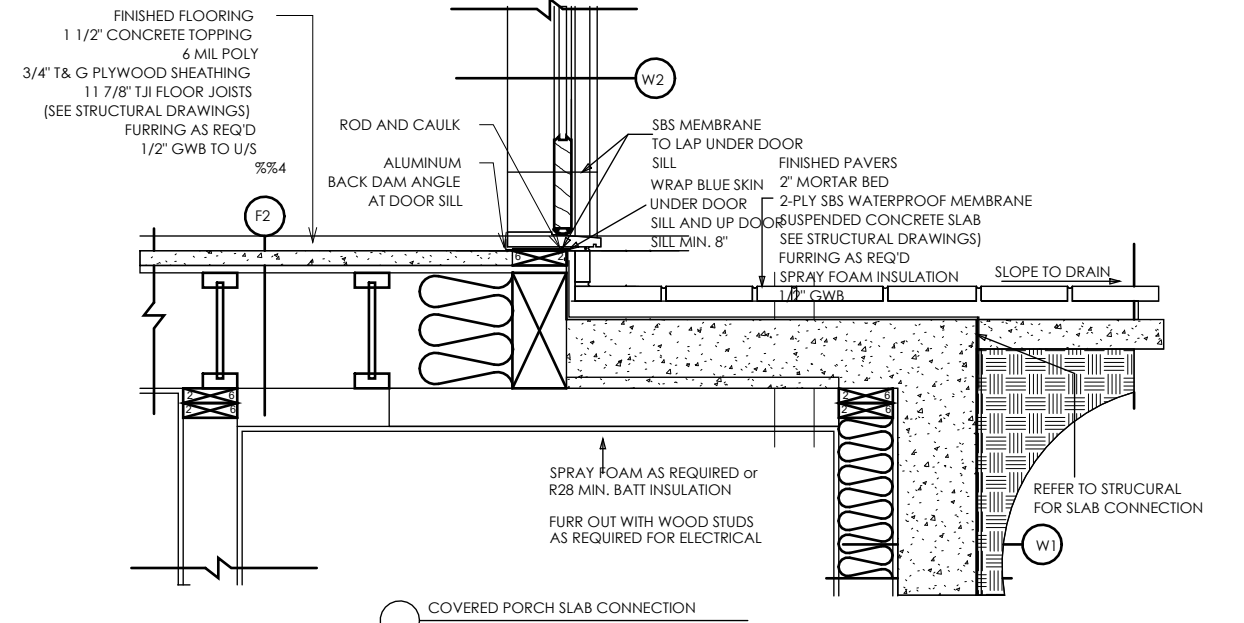

COVERED PORCH SLAB CONNECTION
SCALE 1" = 8"

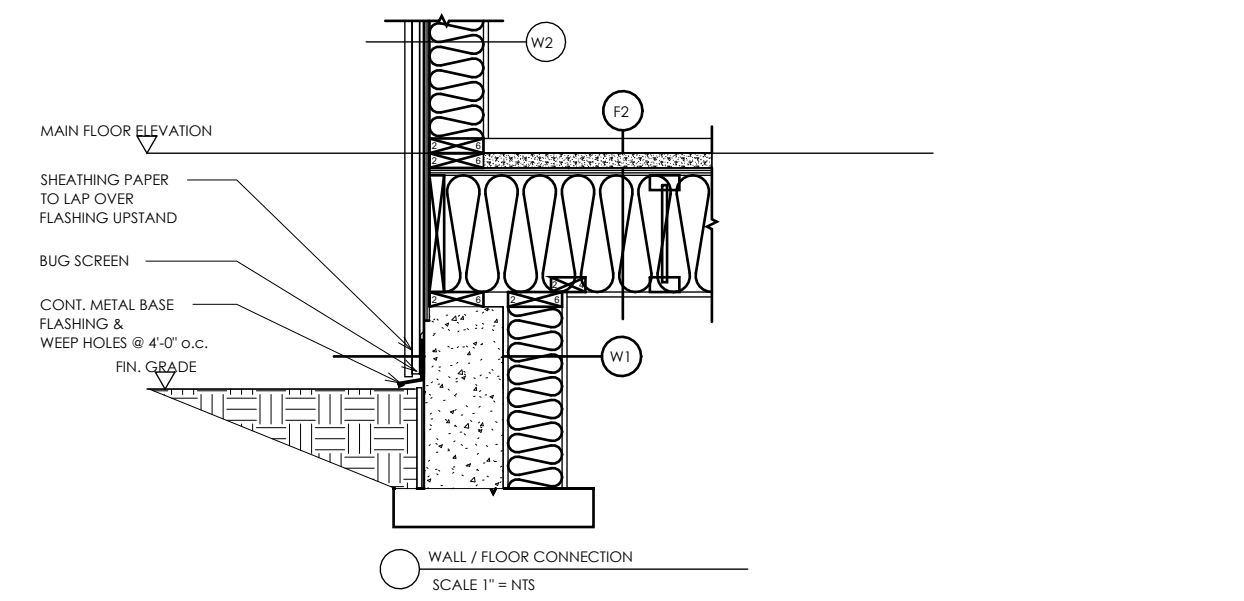

WALL / FLOOR CONNECTION
SCALE 1" = 8"

REVISIONS	
ISSUED FOR:	IFR
REVIEW SET:	2024-06-26 3:09:14 PM

PROJECT:	LOT B 332 E 24TH NORTH VANCOUVER
DRAWING TITLE:	DETAILS

SHEET:	A110
--------	-------------

DRAWN BY:	JP
24X36 SCALE:	As indicated
PROJECT NUMBER:	038821
START DATE:	05.27.24

COPYRIGHT RESERVED.
THIS DRAWING AND DESIGN ARE AND SHALL AT ALL TIMES REMAIN THE EXCLUSIVE PROPERTY OF ROBERT BLANEY DESIGN AND CANNOT BE USED OR REPRODUCED WITHOUT WRITTEN CONSENT. WRITTEN DIMENSIONS SHALL HAVE PRECEDENCE OVER SCALED DIMENSIONS. CONTRACTOR SHALL VERIFY AND SHALL BE RESPONSIBLE FOR ALL DIMENSIONS AND CONDITIONS ON THE JOB AND THIS OFFICE SHALL BE INFORMED OF ANY VARIATIONS FROM THE DIMENSIONS AND CONDITIONS AS SHOWN ON THIS DRAWING. CONTRACTORS SHALL ENSURE THAT ALL CONSTRUCTION WILL COMPLY TO ALL APPLICABLE BUILDING CODES. ROBERT BLANEY DESIGN WILL NOT ACCEPT RESPONSIBILITY FOR VARIATIONS OR MODIFICATION OF THESE PLANS.



5464 PATRICIA BAY HIGHWAY,
VICTORIA BC V8Y 2N9
(604) 626-6020
ROBERTBLANEYDESIGN@GMAIL.COM
WWW.ROBERTBLANEYDESIGN.COM

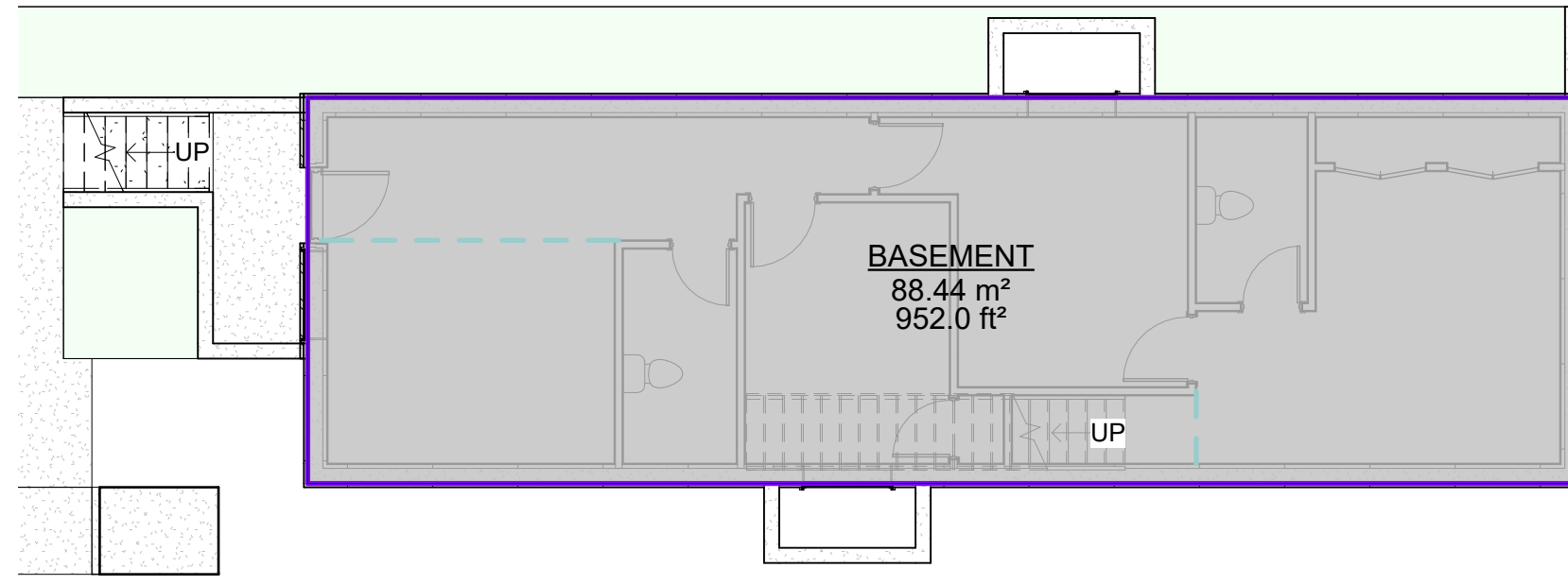

3 BASEMENT
1 : 96

Area Schedule (Gross Building)			
Name	Area	Level	Perimeter
2ND FLOOR	79.54 m ²	2ND FLOOR	43.28 m
MAIN FLOOR	82.31 m ²	MAIN FLOOR	44.50 m
BASEMENT	88.44 m ²	BASEMENT	44.50 m
GARAGE	35.30 m ²	MAIN FLOOR	23.77 m
GARAGE SUITE	35.30 m ²	2ND FLOOR	23.77 m
	320.90 m ²		

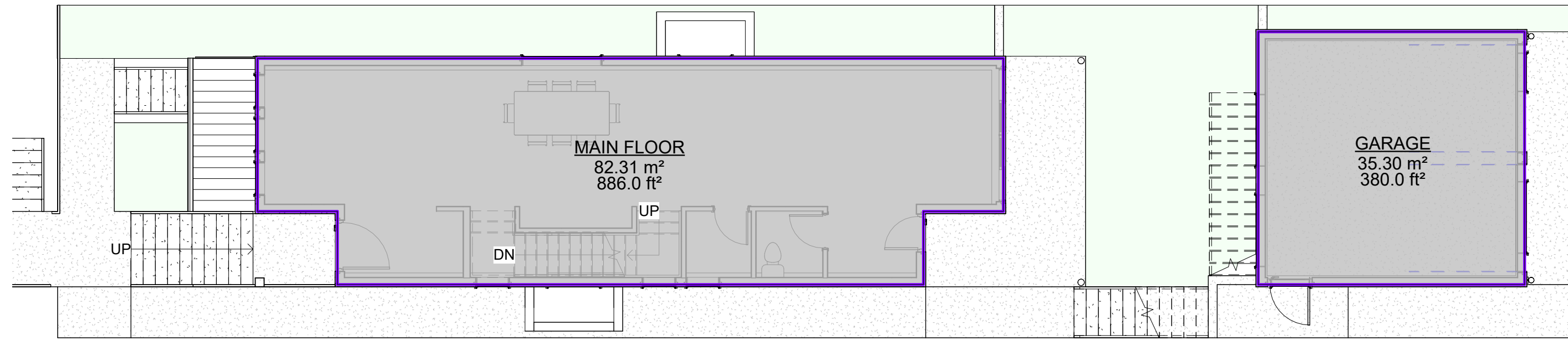

1 MAIN FLOOR
1 : 96

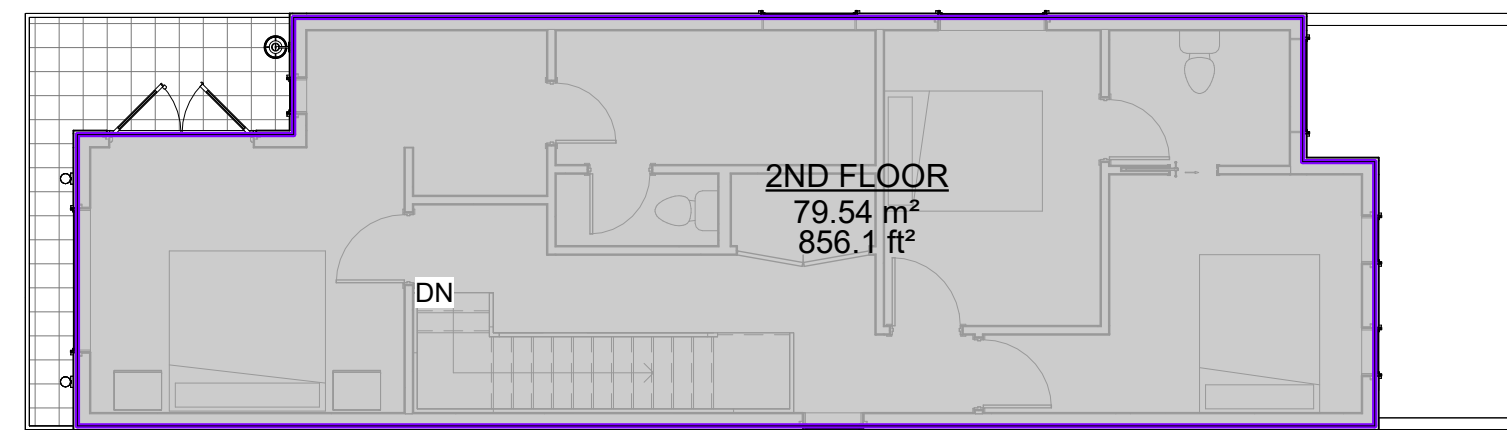

2 2ND FLOOR
1 : 96

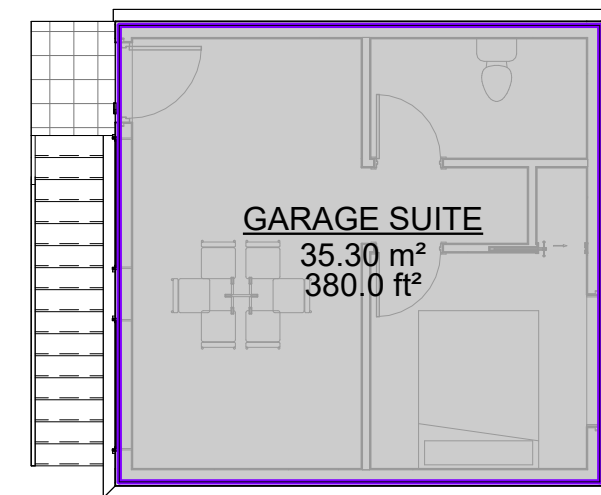



2 GARAGE - NORTH
1 : 48

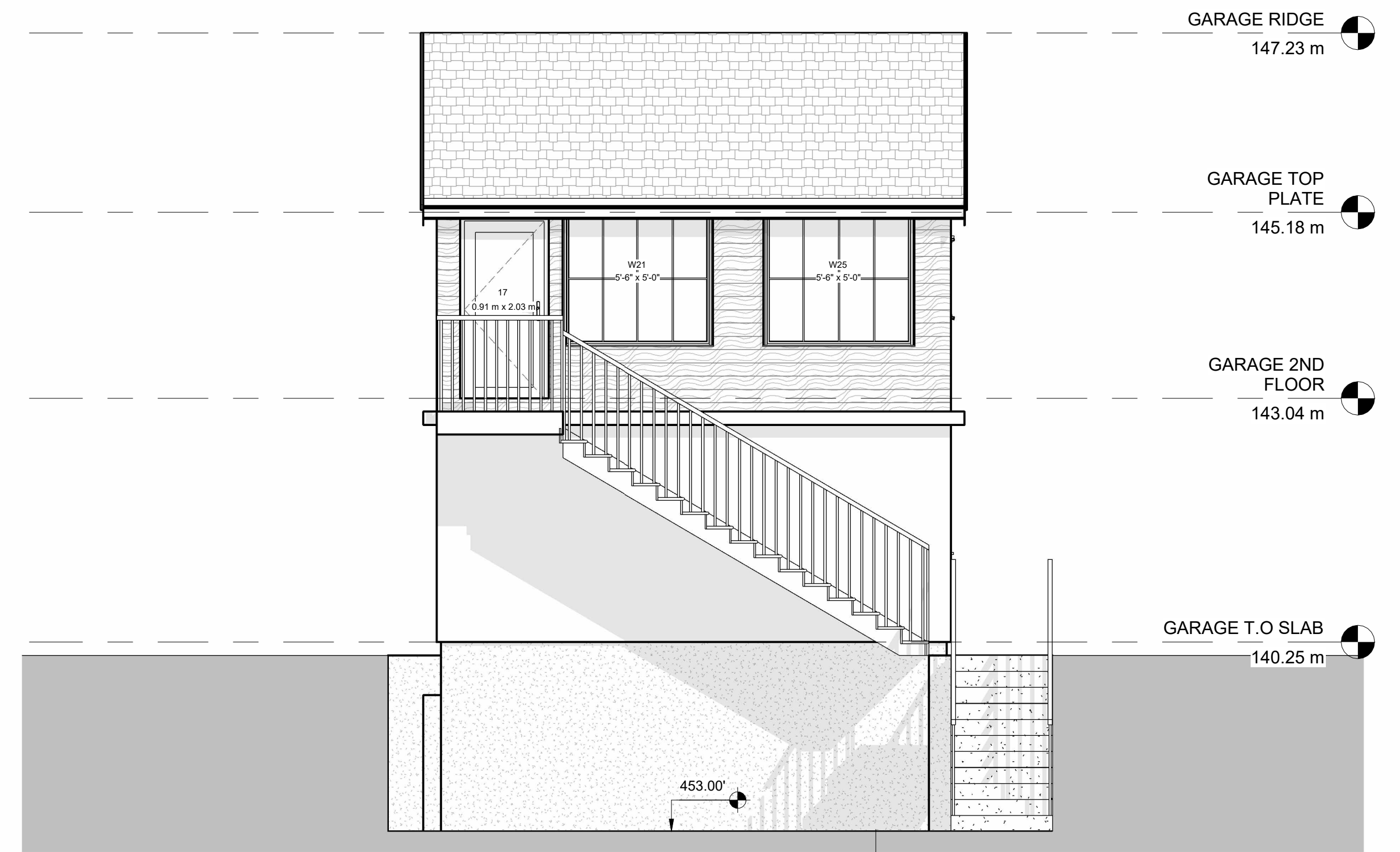
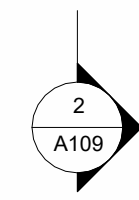

3 GARAGE SOUTH
1 : 48

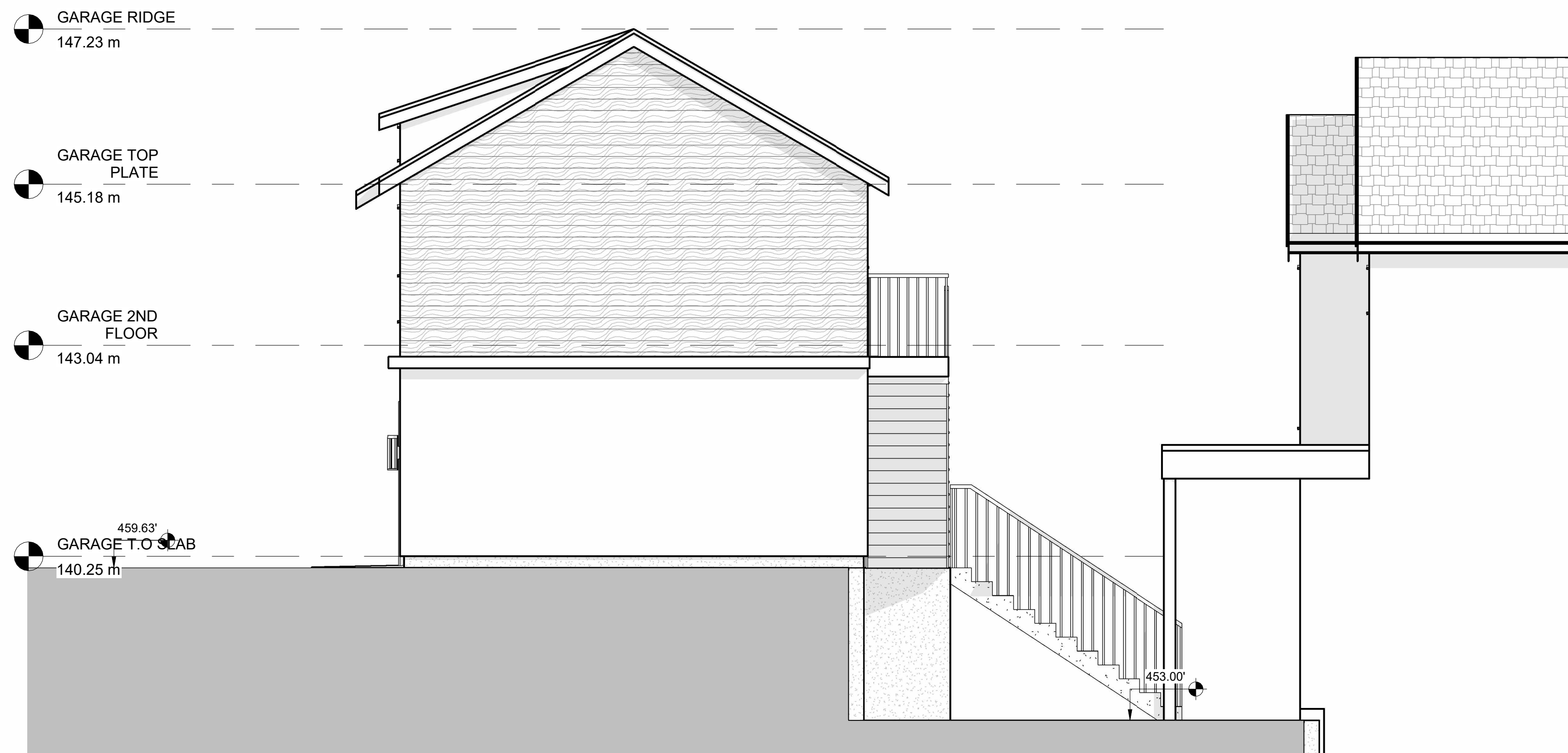
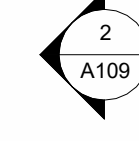

1 GARAGE - EAST
1 : 48

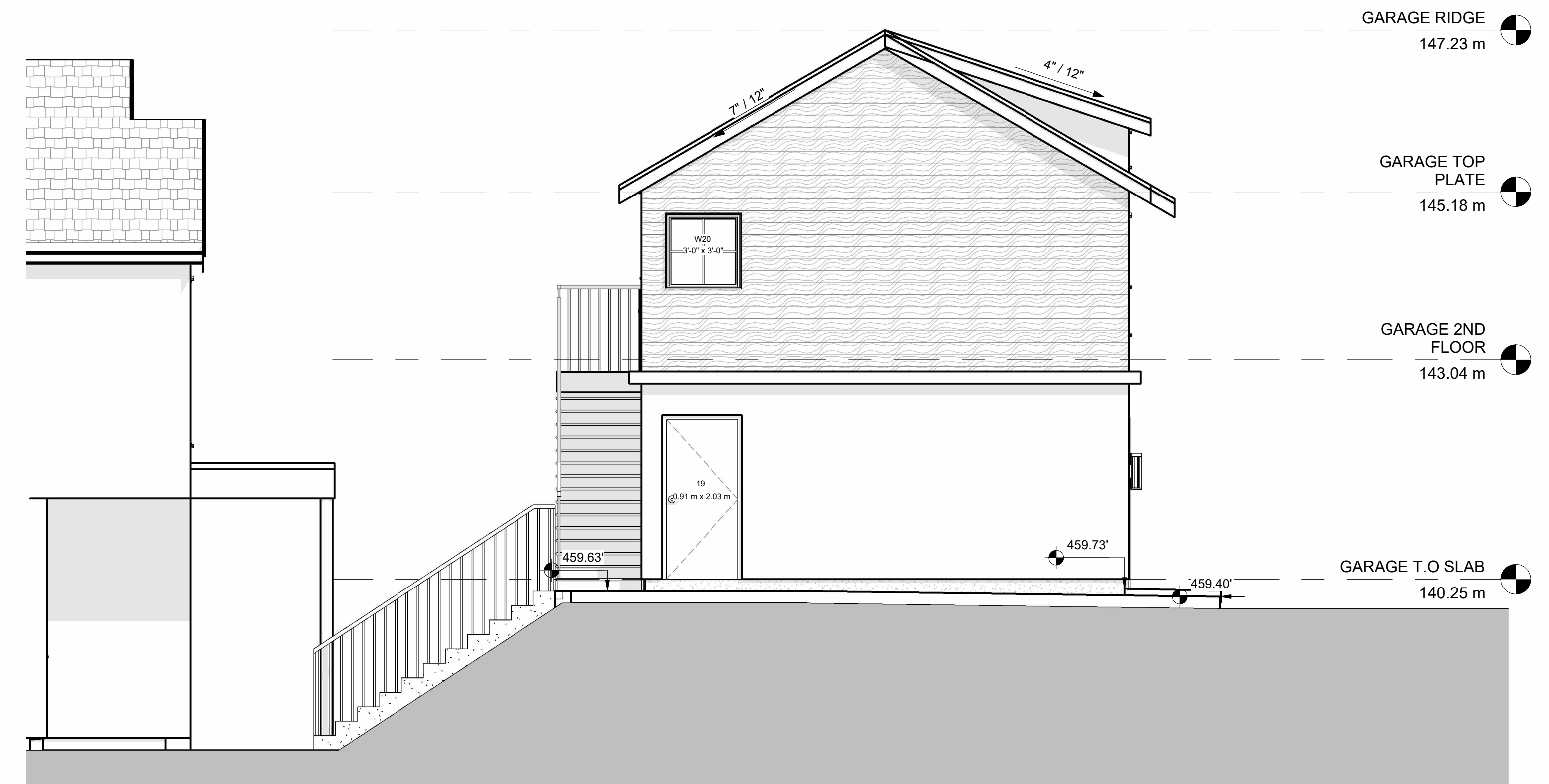

4 GARAGE WEST
1 : 48



PROPERTY TO BE DEVELOPED
332 24TH ST E

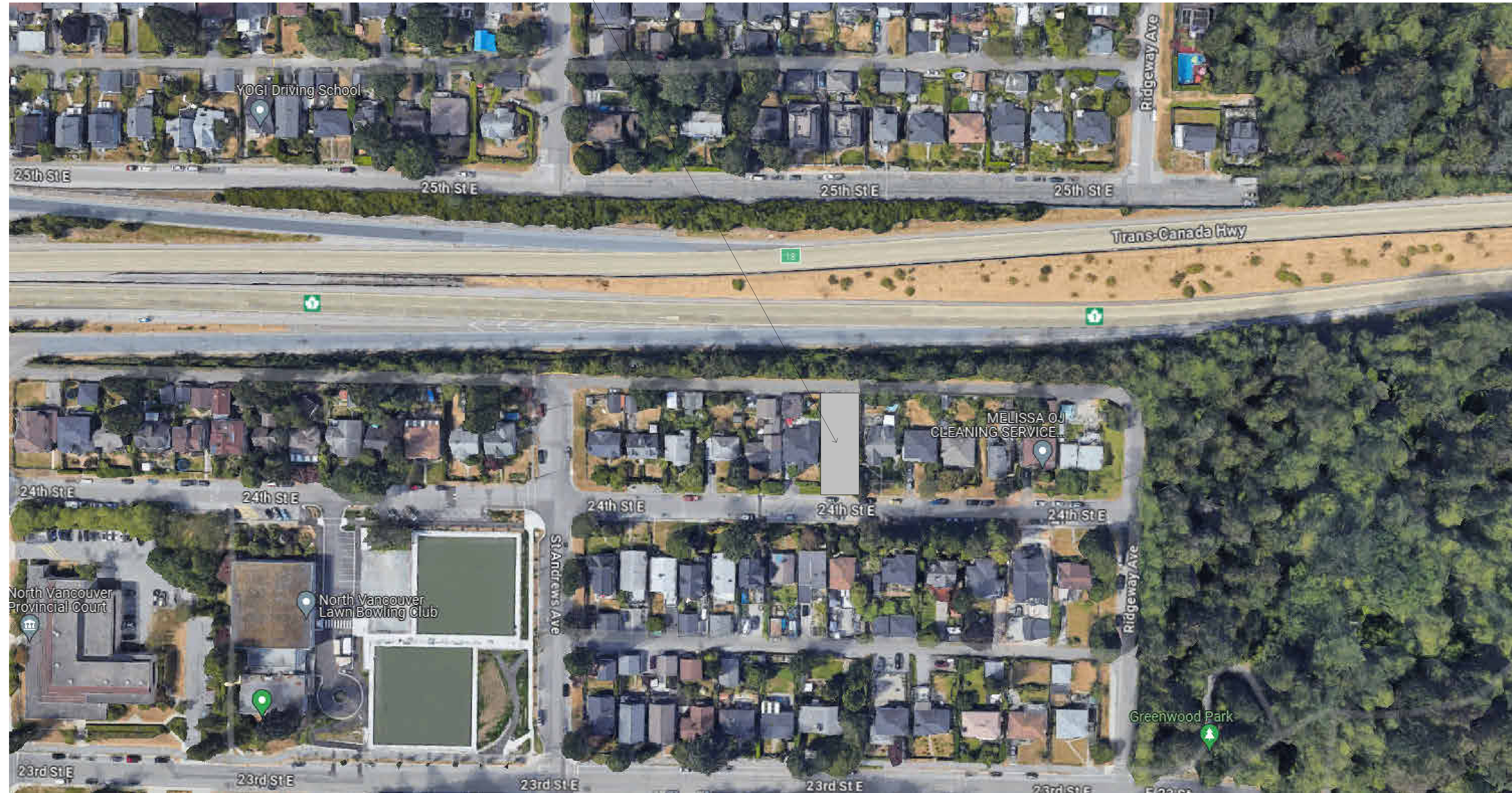

5464 PATRICIA BAY HIGHWAY,
VICTORIA BC V8Y 2N9

(604) 626-6020
ROBERTBLANEYDESIGN@GMAIL.COM
WWW.ROBERTBLANEYDESIGN.COM

REVISIONS
ISSUED FOR: IFR
REVIEW SET: 2024-06-26 3:03:51 PM

PROJECT:
LOT A
332 E 24TH
NORTH VANCOUVER

DRAWING TITLE:
CONTEXTUAL VIEW -
ARIEL

SHEET:

A113

DRAWN BY:
JP

24X36 SCALE:
1 : 24

START DATE:
05.27.24

PROJECT NUMBER:
038821

COPYRIGHT RESERVED.

THIS DRAWING AND DESIGN ARE AND SHALL AT ALL TIMES REMAIN THE EXCLUSIVE PROPERTY OF ROBERT BLANEY DESIGN AND CANNOT BE USED OR REPRODUCED WITHOUT WRITTEN CONSENT. WRITTEN DIMENSIONS SHALL HAVE PRECEDENCE OVER SCALED DIMENSIONS. CONTRACTOR SHALL VERIFY AND SHALL BE RESPONSIBLE FOR ALL DIMENSIONS AND CONDITIONS ON THE JOB AND THIS OFFICE SHALL BE INFORMED OF ANY VARIATIONS FROM THE DIMENSIONS AND CONDITIONS AS SHOWN ON THIS DRAWING. CONTRACTORS SHALL ENSURE THAT ALL CONSTRUCTION WILL COMPLY TO ALL APPLICABLE BUILDING CODES. ROBERT BLANEY DESIGN WILL NOT ACCEPT RESPONSIBILITY FOR VARIATIONS OR MODIFICATION OF THESE PLANS.



PROPERTY TO BE DEVELOPED
332 24TH ST E

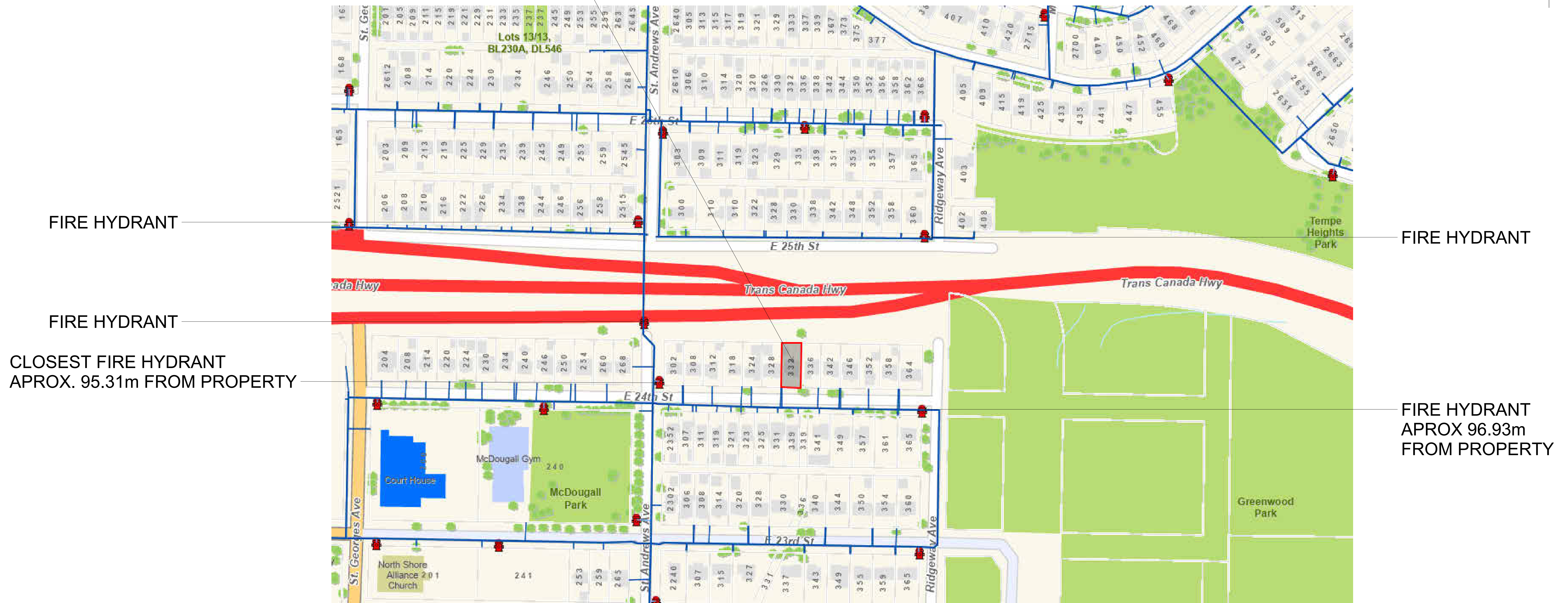

FIRE HYDRANT

FIRE HYDRANT

FIRE HYDRANT

CLOSEST FIRE HYDRANT
APROX. 95.31m FROM PROPERTY

FIRE HYDRANT
APROX 96.93m
FROM PROPERTY



5464 PATRICIA BAY HIGHWAY,
VICTORIA BC V8Y 2N9

(604) 626-6020
ROBERTBLANEYDESIGN@GMAIL.COM
WWW.ROBERTBLANEYDESIGN.COM

REVISIONS
ISSUED FOR: IFR
REVIEW SET: 2024-06-26 3:03:51 PM

PROJECT:
LOT A
332 E 24TH
NORTH VANCOUVER

DRAWING TITLE:
CONTEXTUAL- FIRE
HYDRANTS

SHEET:

A113.1

DRAWN BY:

JP

24X36 SCALE:

1:24

PROJECT NUMBER:

038821

START DATE:

05.27.24

COPYRIGHT RESERVED.
THIS DRAWING AND DESIGN ARE AND SHALL AT ALL TIMES REMAIN THE EXCLUSIVE PROPERTY OF ROBERT BLANEY DESIGN AND CANNOT BE USED OR REPRODUCED WITHOUT WRITTEN CONSENT. WRITTEN DIMENSIONS SHALL HAVE PRECEDENCE OVER SCALED DIMENSIONS. CONTRACTOR SHALL VERIFY AND SHALL BE RESPONSIBLE FOR ALL DIMENSIONS AND CONDITIONS ON THE JOB AND THIS OFFICE SHALL BE INFORMED OF ANY VARIATIONS FROM THE DIMENSIONS AND CONDITIONS AS SHOWN ON THIS DRAWING. CONTRACTORS SHALL ENSURE THAT ALL CONSTRUCTION WILL COMPLY TO ALL APPLICABLE BUILDING CODES. ROBERT BLANEY DESIGN WILL NOT ACCEPT RESPONSIBILITY FOR VARIATIONS OR MODIFICATION OF THESE PLANS.

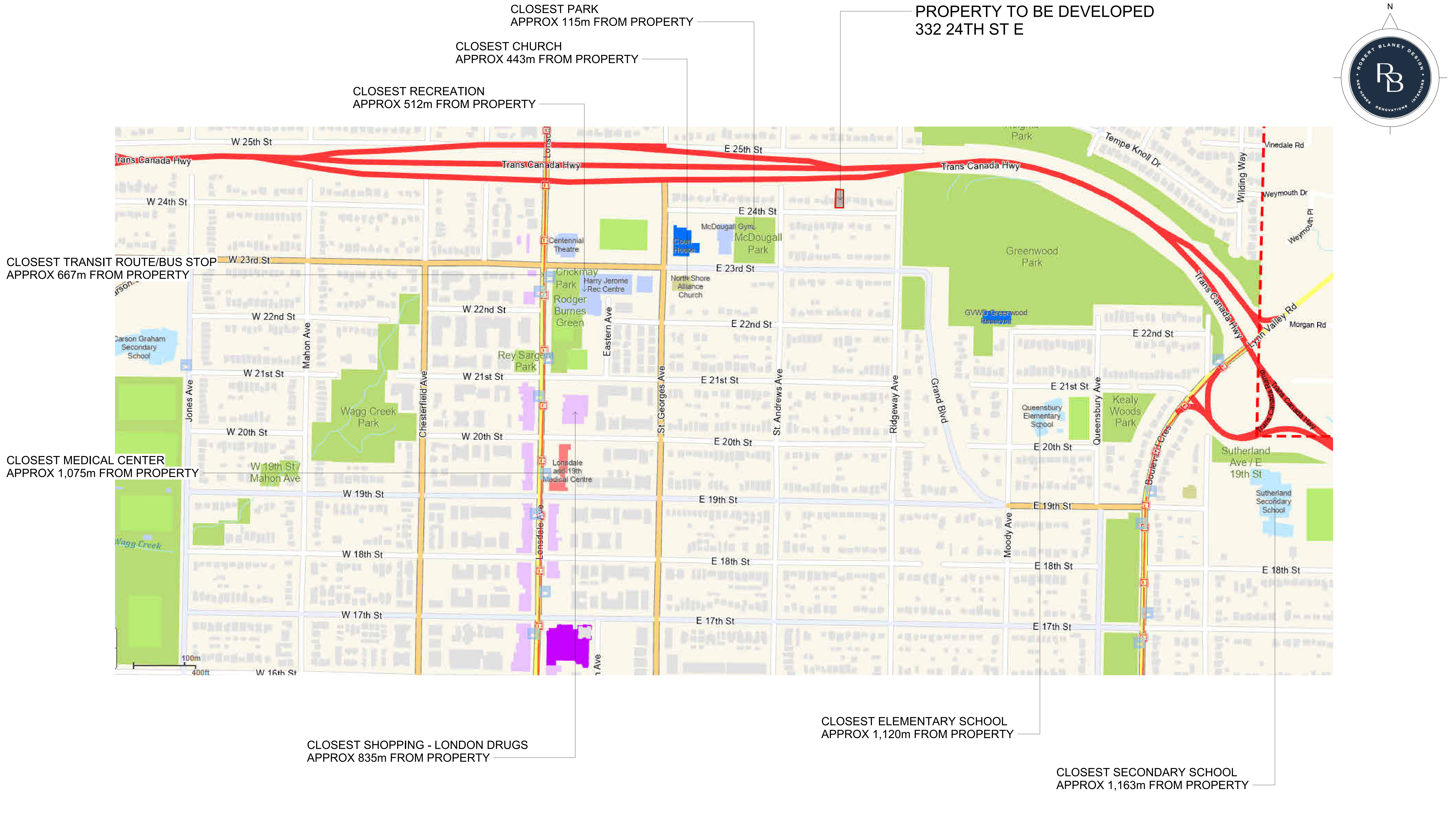

5464 PATRICIA BAY HIGHWAY,
VICTORIA BC V8Y 2N9

(604) 626-6020
ROBERTBLANEYDESIGN@GMAIL.COM
WWW.ROBERTBLANEYDESIGN.COM

REVISIONS

ISSUED FOR: IFR

REVIEW SET: 2024-06-26 3:03:51 PM

PROJECT:

LOT A
332 E 24TH
NORTH VANCOUVER

DRAWING TITLE:
CONTEXTUAL-
AMENITIES

SHEET:

A113.2

DRAWN BY:
JP

24X36 SCALE: 1:40

PROJECT NUMBER:
038821

START DATE:
05.27.24

COPYRIGHT RESERVED.

THIS DRAWING AND DESIGN ARE AND SHALL AT ALL TIMES REMAIN THE EXCLUSIVE PROPERTY OF ROBERT BLANEY DESIGN AND CANNOT BE USED OR REPRODUCED WITHOUT WRITTEN CONSENT. WRITTEN DIMENSIONS SHALL HAVE PRECEDENCE OVER SCALED DIMENSIONS. CONTRACTOR SHALL VERIFY AND SHALL BE RESPONSIBLE FOR ALL DIMENSIONS AND CONDITIONS ON THE JOB AND THIS OFFICE SHALL BE INFORMED OF ANY VARIATIONS FROM THE DIMENSIONS AND CONDITIONS AS SHOWN ON THIS DRAWING. CONTRACTORS SHALL ENSURE THAT ALL CONSTRUCTION WILL COMPLY TO ALL APPLICABLE BUILDING CODES. ROBERT BLANEY DESIGN WILL NOT ACCEPT RESPONSIBILITY FOR VARIATIONS OR MODIFICATION OF THESE PLANS.